

WIRELESS SPEAKER

Denon Home 350



[Click here!](#)

On-line service parts list

<https://dmedia.soundunited.com/documents/details/26501>

[ONLINE PARTS LIST \(P5\)](#)

WEB owner's manual

NA: <http://manuals.denon.com/DenonHome350/NA/EN/index.php>

EU: <http://manuals.denon.com/DenonHome350/EU/EN/index.php>

AP: <http://manuals.denon.com/DenonHome350/AP/ZH/index.php>

Upload is planned for the time of a future press release.

BEFORE SERVICING THIS UNIT

ELECTRICAL

MECHANICAL

REPAIR INFORMATION

UPDATING

- For purposes of improvement, specifications and design are subject to change without notice.
- Please use this service manual when referring to the operating instructions without fail.
- Some illustrations used in this service manual are slightly different from the actual product.

Confidential

BEFORE SERVICING THIS UNIT

SAFETY PRECAUTIONS

NOTE FOR SCHEMATIC DIAGRAM

HANDLING THE SEMICONDUCTOR AND OPTICS

ONLINE PARTS LIST

[Accessing the Parts List](#)

[Searching Part Numbers or Ref. Numbers](#)

[NOTE FOR PARTS LIST](#)

SERIAL NUMBER

[Serial Number Organization](#)

[SKU Code of this Unit](#)

POST-SERVICE PRECAUTIONS

[Initializing this Unit](#)

SAFETY PRECAUTIONS

The following items should be checked for continued protection of the customer and the service technician.

Leakage current check

Before returning the set to the customer, be sure to carry out either (1) a leakage current check or (2) a line to chassis resistance check. If the leakage current exceeds 0.5 milliamps, or if the resistance from chassis to either side of the power cord is less than 460 kohms, the set is defective.

Be sure to test for leakage current with the AC plug in both polarities, in addition, when the set's power is in each state (on, off and standby mode), if applicable.

CAUTION

Please heed the following cautions and instructions during servicing and inspection.

⊙ Heed the cautions!

Cautions which are delicate in particular for servicing are labeled on the cabinets, the parts and the chassis, etc. Be sure to heed these cautions and the cautions described in the handling instructions.

⊙ Cautions concerning electric shock!

- (1) An AC voltage is impressed on this set, so if you touch internal metal parts when the set is energized, you may get an electric shock. Avoid getting an electric shock, by using an isolating transformer and wearing gloves when servicing while the set is energized, or by unplugging the power cord when replacing parts, for example.
- (2) There are high voltage parts inside. Handle with extra care when the set is energized.

⊙ Caution concerning disassembly and assembly!

Through great care is taken when parts were manufactured from sheet metal, there may be burrs on the edges of parts. The burrs could cause injury if fingers are moved across them in some rare cases. Wear gloves to protect your hands.

⊙ Use only designated parts!

The set's parts have specific safety properties (fire resistance, voltage resistance, etc.). Be sure to use parts which have the same properties for replacement. The burrs have the same properties. In particular, for the important safety parts that are indicated by the \triangle mark on schematic diagrams and parts lists, be sure to use the designated parts.

⊙ Be sure to mount parts and arrange the wires as they were originally placed!

For safety reasons, some parts use tapes, tubes or other insulating materials, and some parts are mounted away from the surface of printed circuit boards. Care should also be taken with the positions of the wires by arranging them and using clamps to keep them away from heating and high voltage parts, so be sure to set everything back as it was originally placed.

⊙ Make a safety check after servicing!

Check that all screws, parts and wires removed or disconnected when servicing have been put back in their original positions, check that no serviced parts have deteriorated the area around. Then make an insulation, check on the external metal connectors and between the blades of the power plug. And otherwise check that safety is ensured.

(Insulation check procedure)

Unplug the power cord from the power outlet, disconnect the antenna, plugs, etc., and on the power. Using a 500V insulation resistance tester, check that the insulation resistance value between the inplug and the externally exposed metal parts (antenna terminal, headphones terminal, input terminal, etc.) is 1M Ω or greater. If it is less, the set must be inspected and repaired.

CAUTION

Concerning important safety parts

Many of the electric and the structural parts used in the set have special safety properties. In most cases these properties are difficult to distinguish by sight, and the use of replacement parts with higher ratings (rated power and withstand voltage) does not necessarily guarantee that safety performance will be preserved. Parts with safety properties are indicated as shown below on the wiring diagrams and the parts list in this service manual. Be sure to replace them with the parts which have the designated part number.

- (1) Schematic diagrams Indicated by the \triangle mark.
- (2) Parts lists Indicated by the \triangle mark.

The use of parts other than the designated parts could cause electric shocks, fires or other dangerous situations.

NOTE FOR SCHEMATIC DIAGRAM

WARNING:

Parts indicated by the \triangle mark have critical characteristics. Use ONLY replacement parts recommended by the manufacturer.

CAUTION:

Before returning the set to the customer, be sure to carry out either (1) a leakage current check or (2) a line to chassis resistance check. If the leakage current exceeds 0.5 milliamps, or if the resistance from chassis to either side of the power cord is less than 460 kohms, the set is defective.

WARNING:

DO NOT return the set to the customer unless the problem is identified and remedied.

NOTICE:

- (1) ALL RESISTANCE VALUES IN OHM. k=1,000 OHM / M=1,000,000 OHM
- (2) ALL CAPACITANCE VALUES ARE EXPRESSED IN MICRO FARAD, UNLESS OTHERWISE INDICATED. P INDICATES MICRO-MICRO FARAD. N INDICATES NANO FARAD.
- (3) EACH VOLTAGE AND CURRENT ARE MEASURED AT NO SIGNAL INPUT CONDITION.
- (4) CIRCUIT AND PARTS ARE SUBJECT TO CHANGE WITHOUT PRIOR NOTICE.

HANDLING THE SEMICONDUCTOR AND OPTICS

Electrostatic breakdown of the semi-conductors or optical pickup may occur due to a potential difference caused by electrostatic charge during unpacking or repair work.

1. Ground for Human Body

Be sure to wear a grounding band (1 M ohm) that is properly grounded to remove any static electricity that may be charged on the body.

2. Ground for Workbench

Be sure to place a conductive sheet or copper plate with proper grounding (1 M ohm) on the workbench or other surface, where the semi-conductors are to be placed. Because the static electricity charge on clothing will not escape through the body grounding band, be careful to avoid contacting semi-conductors with your clothing

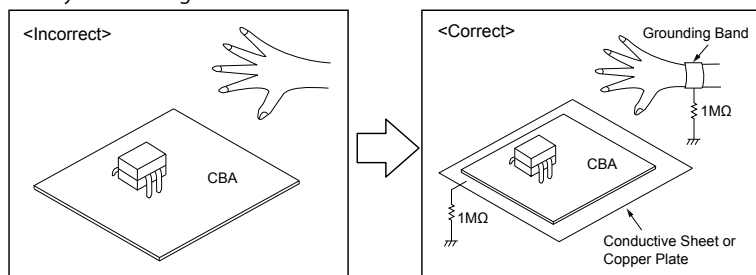

ONLINE PARTS LIST

Accessing the Parts List

- (1) Access from the Service Manual
 - Click the URL link on the cover of the service manual.
Examples of display



NOTE: If the web browser does not open automatically, copy the URL and paste it into the address bar of the web browser and then press Enter.

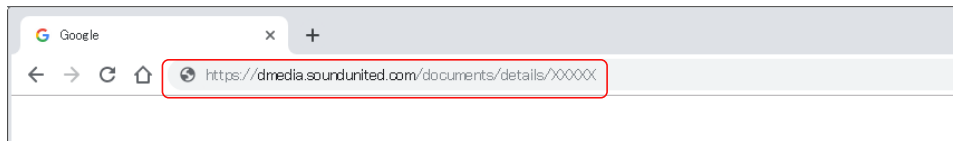

- (2) Accessing the Part List from the Model Asset Screen.
 - Display Model Asset from New SDI.
 - Click the section displayed as ▼ Link to Part Lists under the model name.

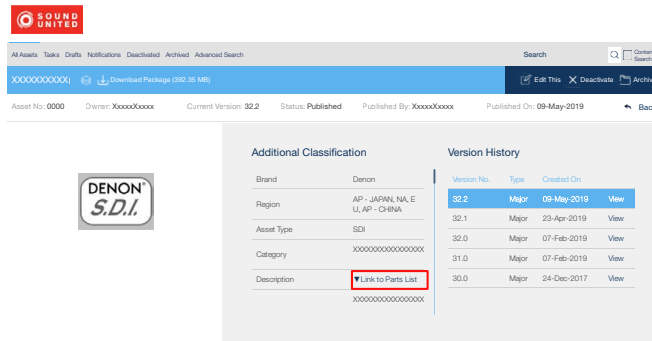

NOTE: If the ▼ Link to Parts List section is not displayed, download the parts table from the Asset list.

Searching Part Numbers or Ref. Numbers

You can search a Parts List for part numbers or Ref. numbers.

- (1) Enter the part number or Ref. number in the search window of the Parts List, and press the search button.
- (2) The search results are displayed.
The name of the sheet in which the search part is used and the part's line are displayed.

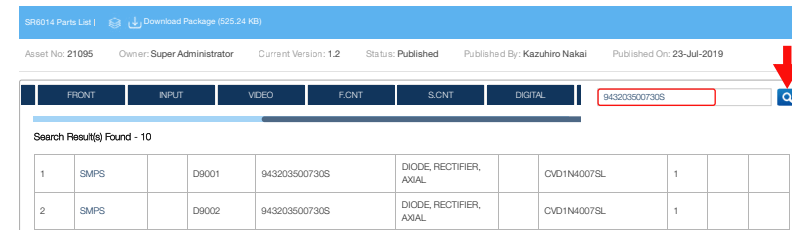

- (3) Next, click the "Sheet" section of the search results.

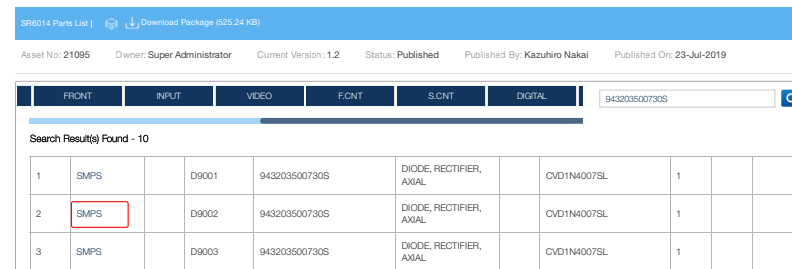

NOTE FOR PARTS LIST

- Parts indicated by "nsp" on this table cannot be supplied.
 - When ordering a part, make a clear distinction between "1" and "l" (i) to avoid mis-supplying.
 - A part ordered without specifying its part number can not be supplied.
 - Part indicated by "@" mark is not illustrated in the exploded and packaging view.
- WARNING:** Parts indicated by the ⚠ mark have critical characteristics. Use ONLY replacement parts recommended by the manufacturer.

SERIAL NUMBER

Serial Number Organization

The 14-digit serial number that contains the code of the manufacturing plant and the manufacturing date.

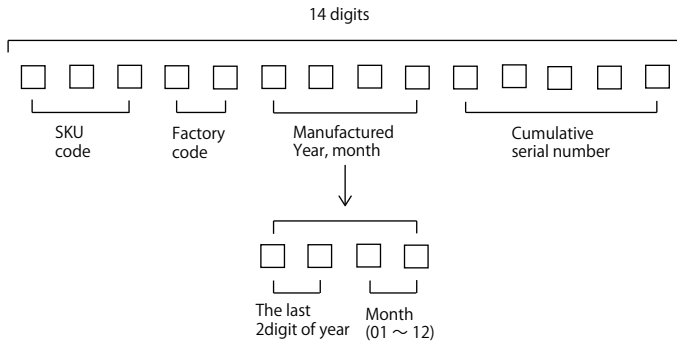

SKU Code of this Unit

Product SKU	SKU Code
DENONHOME350BKE3	BMD
DENONHOME350WTE3	BMF
DENONHOME350BKE2	BME
DENONHOME350WTE2	BMG
DENONHOME350BKE1C	BNL

Initializing this Unit

Make sure to initialize this unit after replacing the microcomputer or any peripheral equipment, or the PCB.

1. Initialize the unit to restore the factory settings.

- (1) Remove the AC plug.
- (2) Insert the AC plug while pressing "**Bluetooth**" button, and wait for more than 5 seconds.
- (3) Check that the Status LEDs is now blinking in orange and then release the button.
- (4) The Status LED blinks in orange while this unit is initializing.
- (5) This unit automatically restarts when initialization is complete.

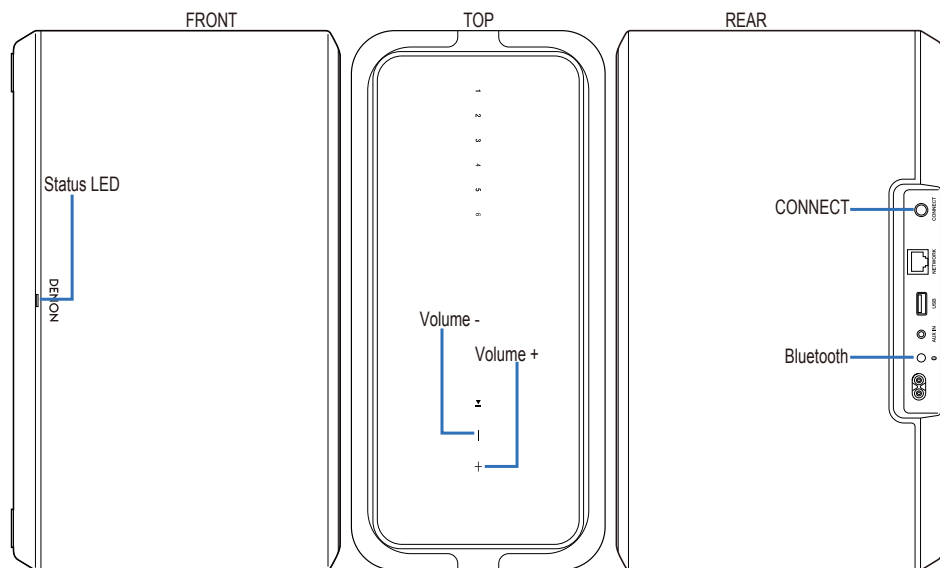

2. Update the firmware.

- (1) Update the firmware via a network or using a USB flash drive.
See "[2. Updating via Network](#)"
See "[3. Updating via USB](#)"

3. Reset the software.

- (1) While the power is on, hold down the "**Bluetooth**" and "**Connect**" buttons for at least 5 seconds.
- (2) Check that the Status LEDs is now blinking in orange and then release the button.
- (3) The Status LED blinks in orange while this unit is initializing.
- (4) This unit automatically restarts when initialization is complete.

ELECTRICAL

SCHEMATIC DIAGRAMS

- [SCH01 MAIN DSP](#)
- [SCH02 MAIN DAMP1](#)
- [SCH03 MAIN DAMP2](#)
- [SCH04 MAIN AUX & USB & ETHERNET](#)
- [SCH05 MAIN SUN MODULE](#)
- [SCH06 MAIN VOICE](#)
- [SCH07 MAIN POWER](#)
- [SCH08 MAIN PLD](#)
- [SCH09 TOUCH & VOICE LED](#)
- [SCH10 SMPS](#)
- [SCH11 SUN_MODULE 01](#)
- [SCH12 SUN_MODULE 02](#)
- [SCH13 SUN_MODULE 03](#)
- [SCH14 SUN_MODULE 04](#)
- [SCH15 SUN_MODULE 05](#)
- [SCH16 SUN_MODULE 06](#)
- [SCH17 SUN_MODULE 07](#)
- [SCH18 SUN_MODULE 08](#)
- [SCH19 SUN_MODULE 09](#)
- [SCH20 SUN_MODULE 10](#)
- [SCH21 SUN_MODULE 11](#)
- [SCH22 SUN_MODULE 12](#)
- [SCH23 SUN_MODULE 13](#)
- [SCH24 SUN_MODULE 14](#)

PRINTED CIRCUIT BOARDS

[TOUCH, MAIN, SMPS, LED, SUN MODULE](#)

BLOCK DIAGRAM

POWER DIAGRAM

WIRING DIAGRAM

SEMICONDUCTORS

[1. IC's](#)

SCHEMATIC DIAGRAMS

SCH01 MAIN DSP

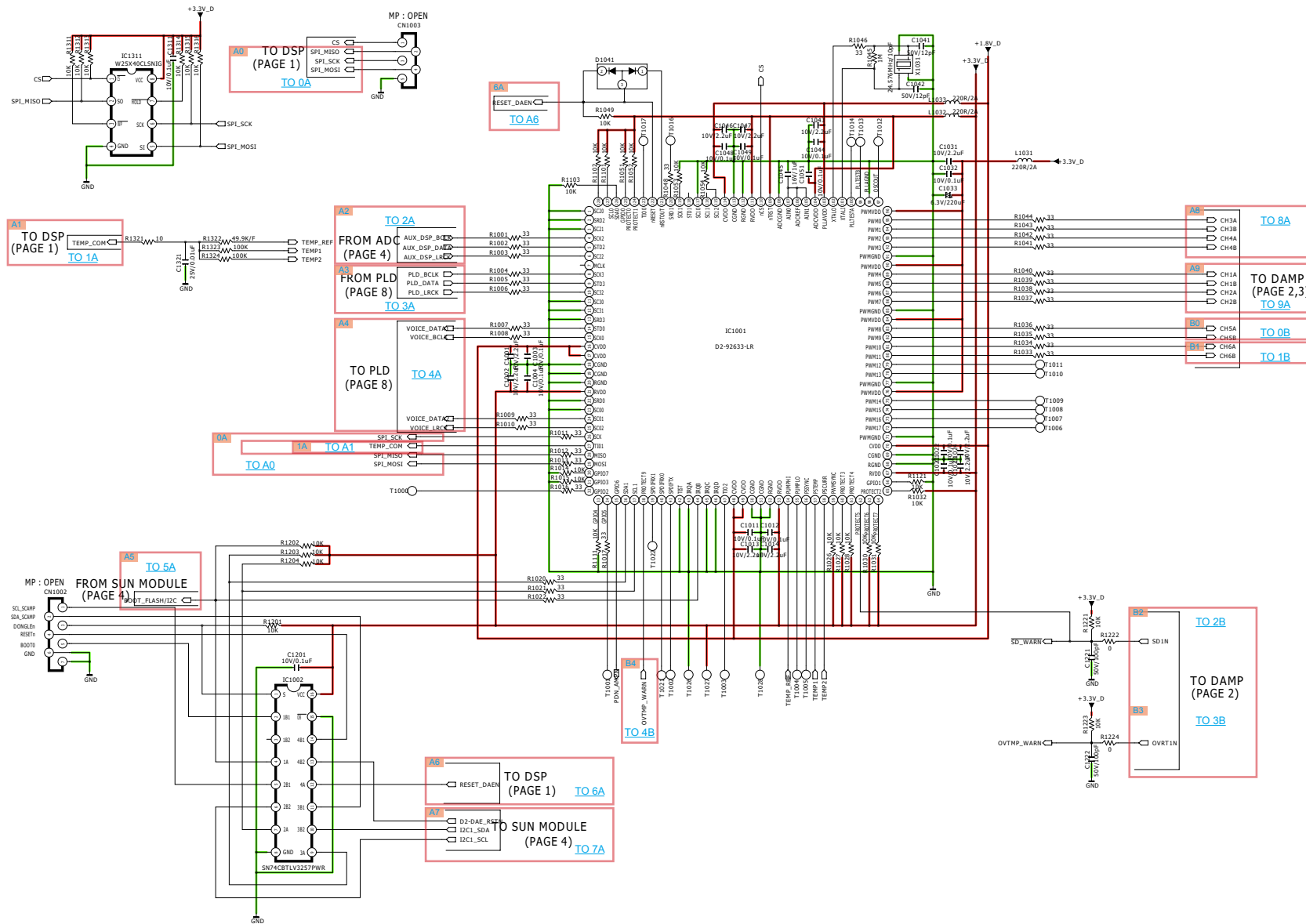

GND LINE POWER+ LINE POWER- LINE ANALOG AUDIO DIGITAL AUDIO STBY POWER

DAMP 1

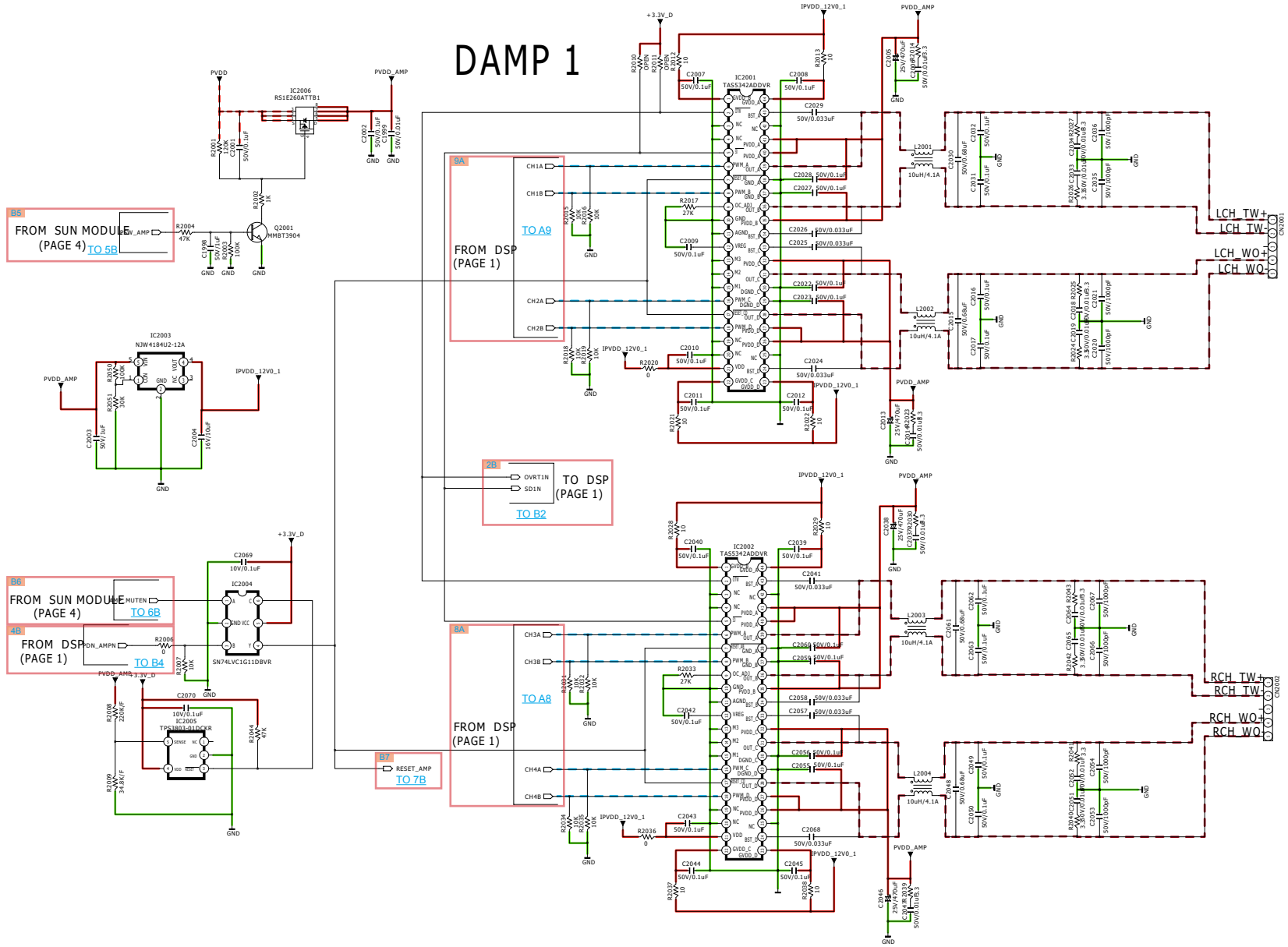

GND LINE POWER+ LINE POWER- LINE ANALOG AUDIO DIGITAL AUDIO STBY POWER

DAMP 2

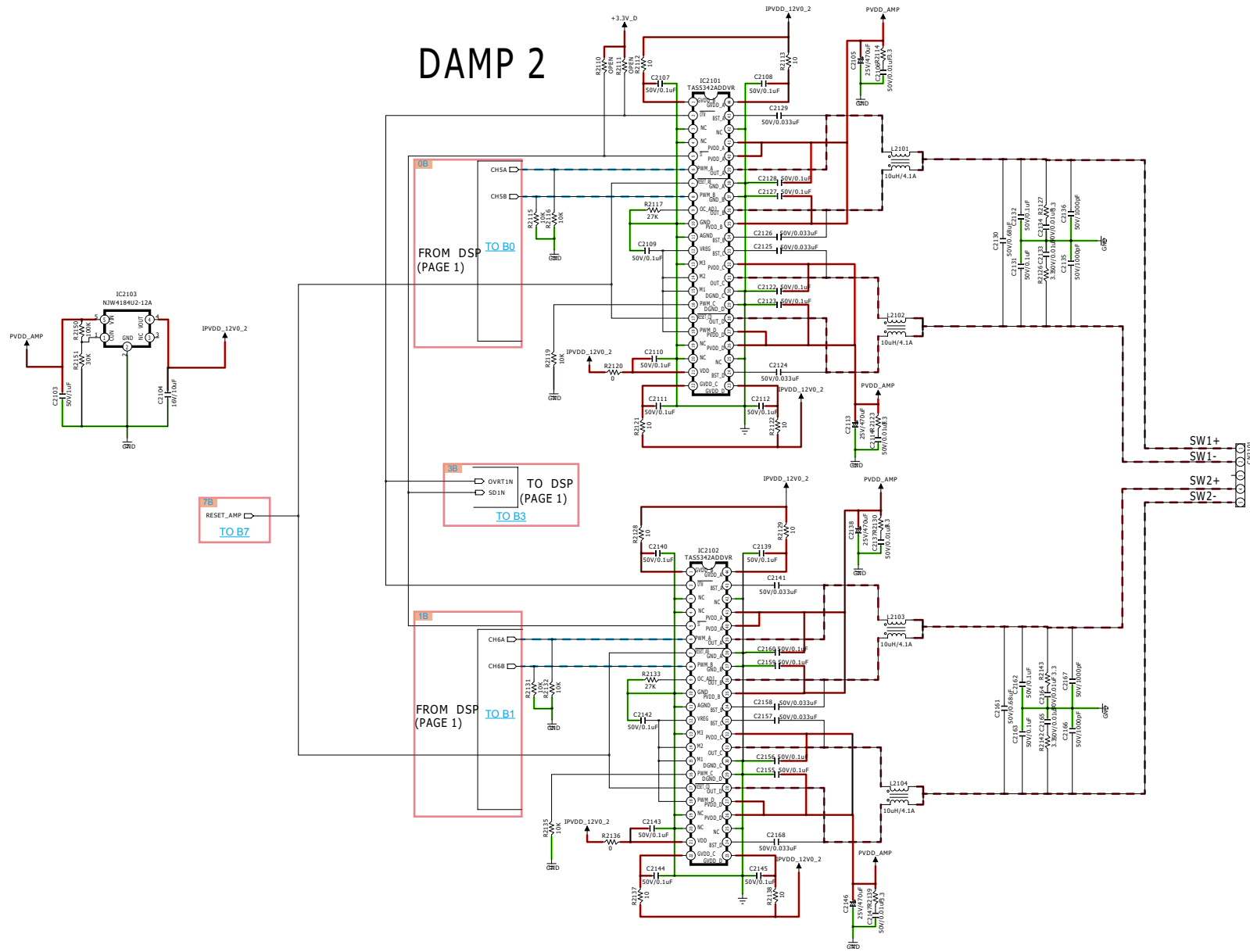

— GND LINE
 — POWER+ LINE
 — POWER- LINE
 — ANALOG AUDIO
 — DIGITAL AUDIO
 — STBY POWER

SCH04 MAIN AUX & USB & ETHERNET

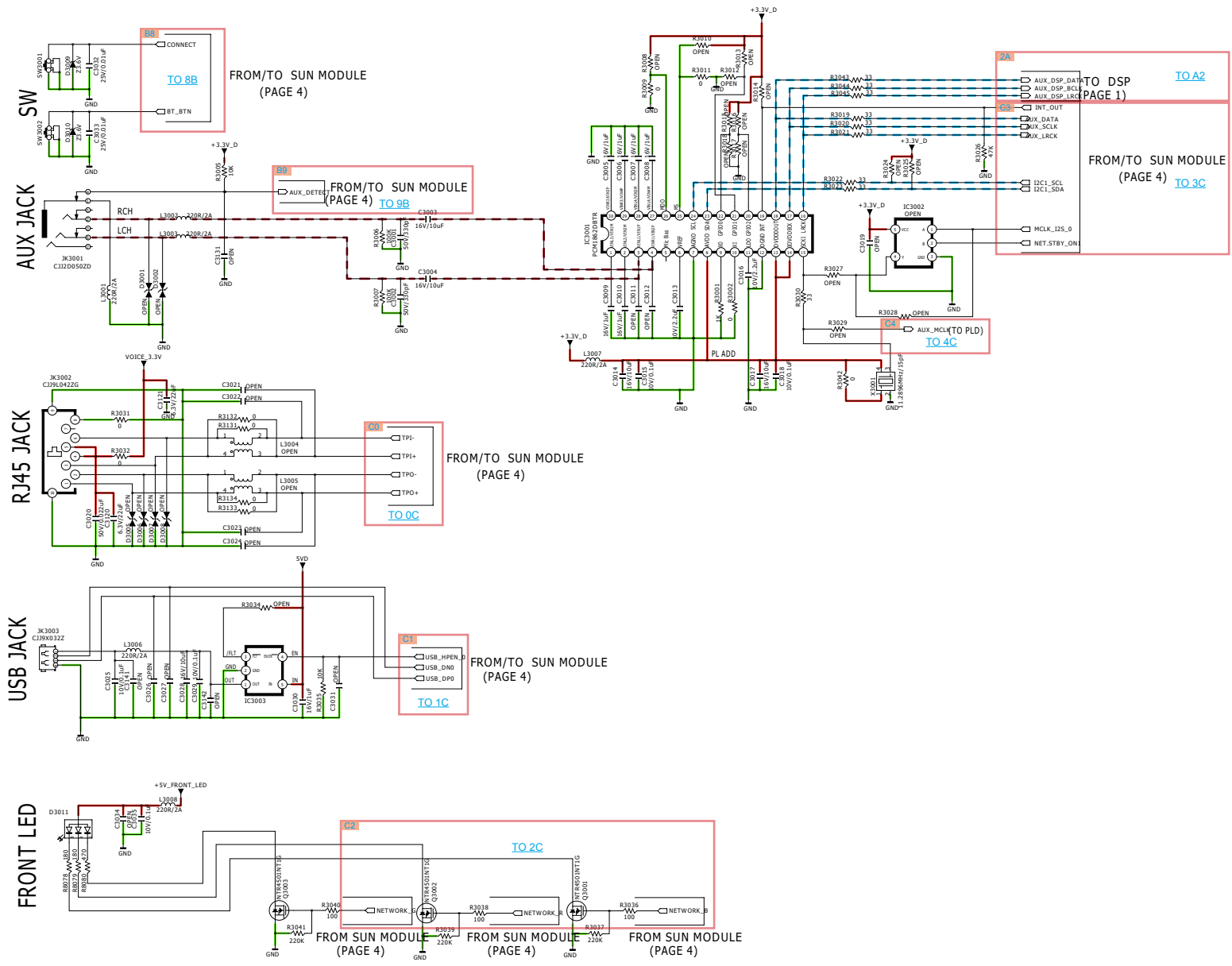

GND LINE POWER+ LINE POWER- LINE ANALOG AUDIO DIGITAL AUDIO STBY POWER

Before Servicing
This Unit

Electrical

Mechanical

Repair Information

Updating

SUN TYPE-S MODULE

DENON HOME	R4096	R4098
150	6.8K	300
250	300	300
350	1K	300

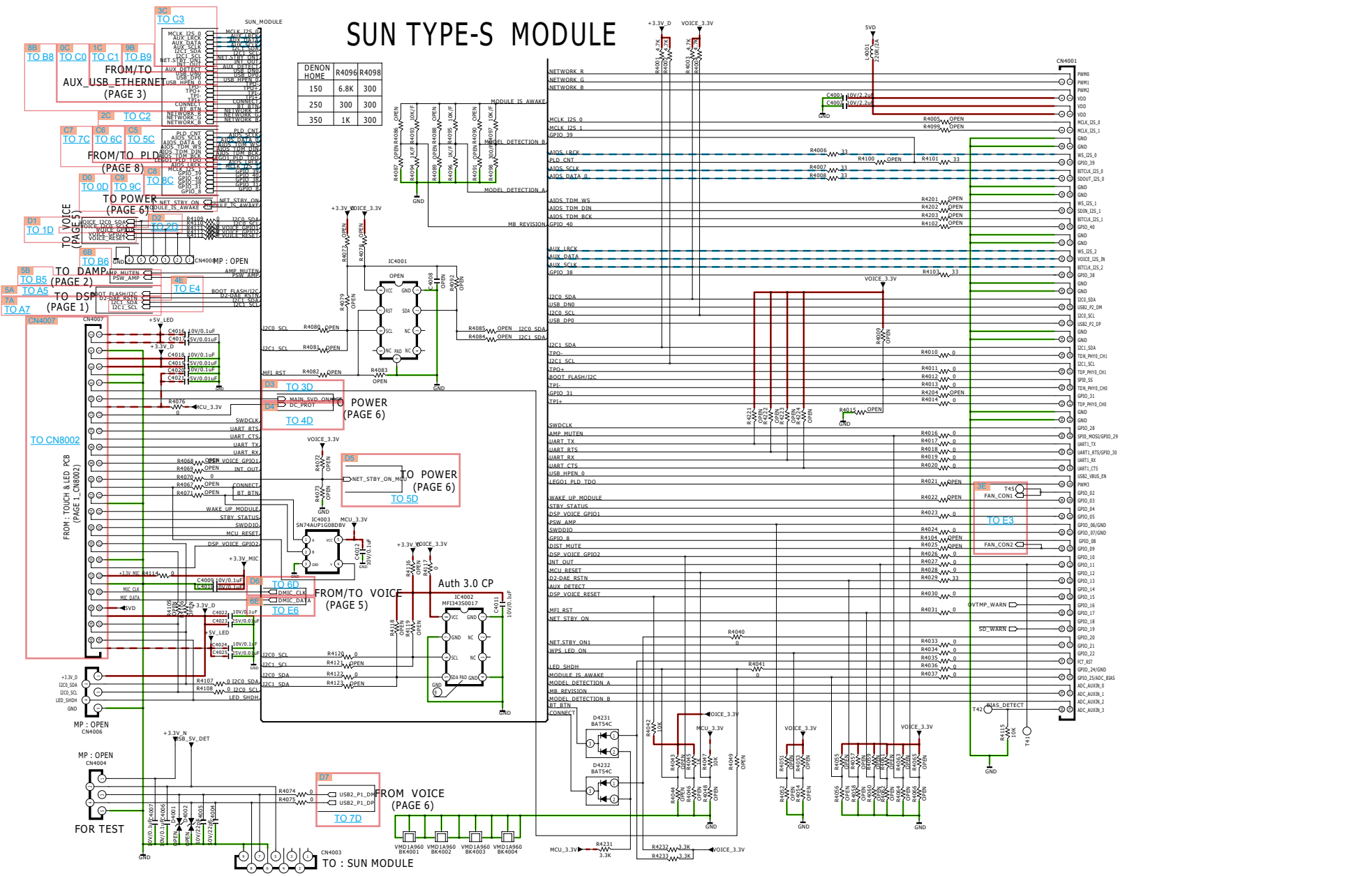

— GND LINE
 — POWER+ LINE
 — POWER- LINE
 — ANALOG AUDIO
 — DIGITAL AUDIO
 — STBY POWER

Before Servicing This Unit

Electrical

Mechanical

Repair Information

Updating

POWER

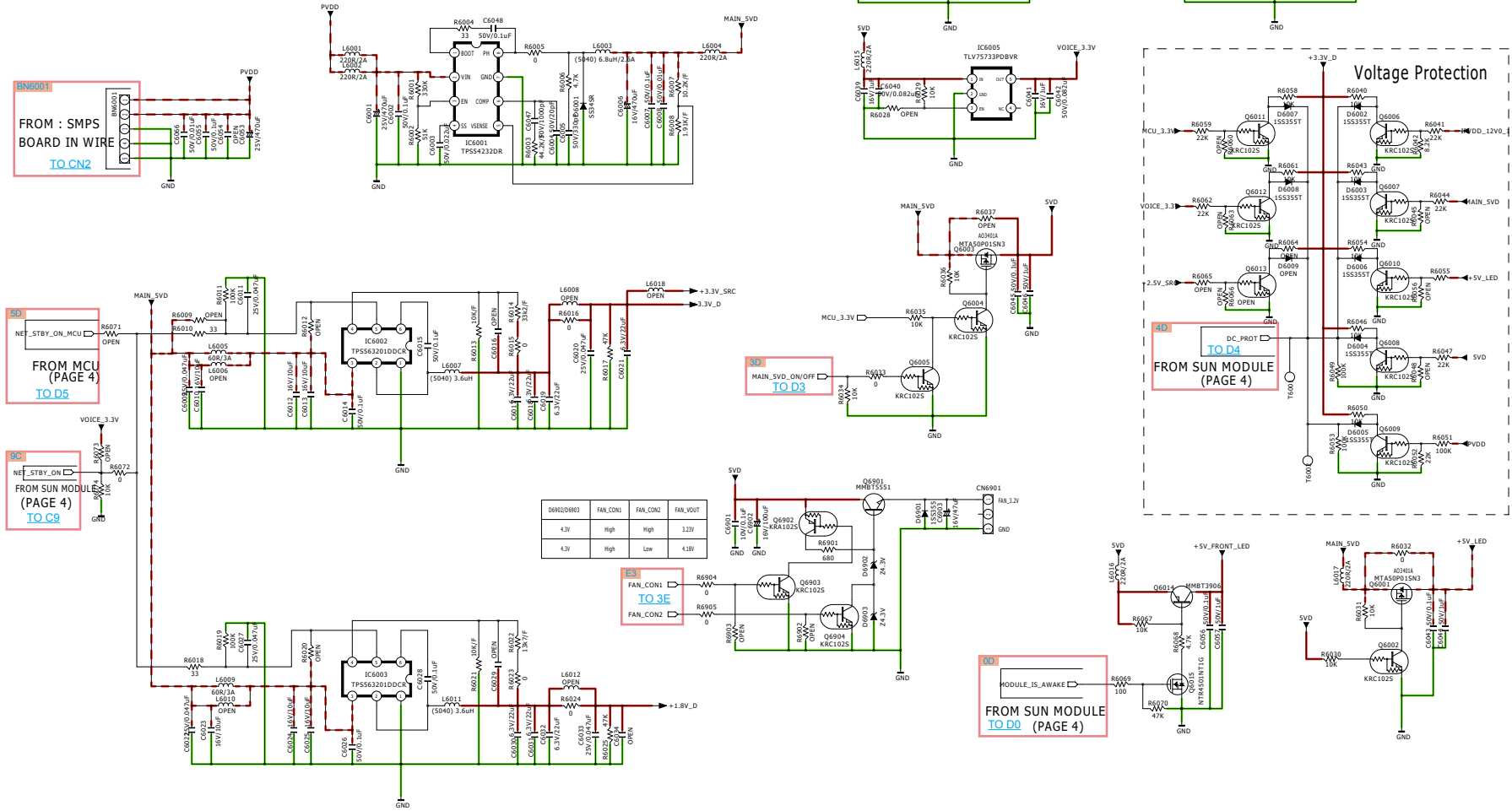

GND LINE POWER+ LINE POWER- LINE ANALOG AUDIO DIGITAL AUDIO STBY POWER

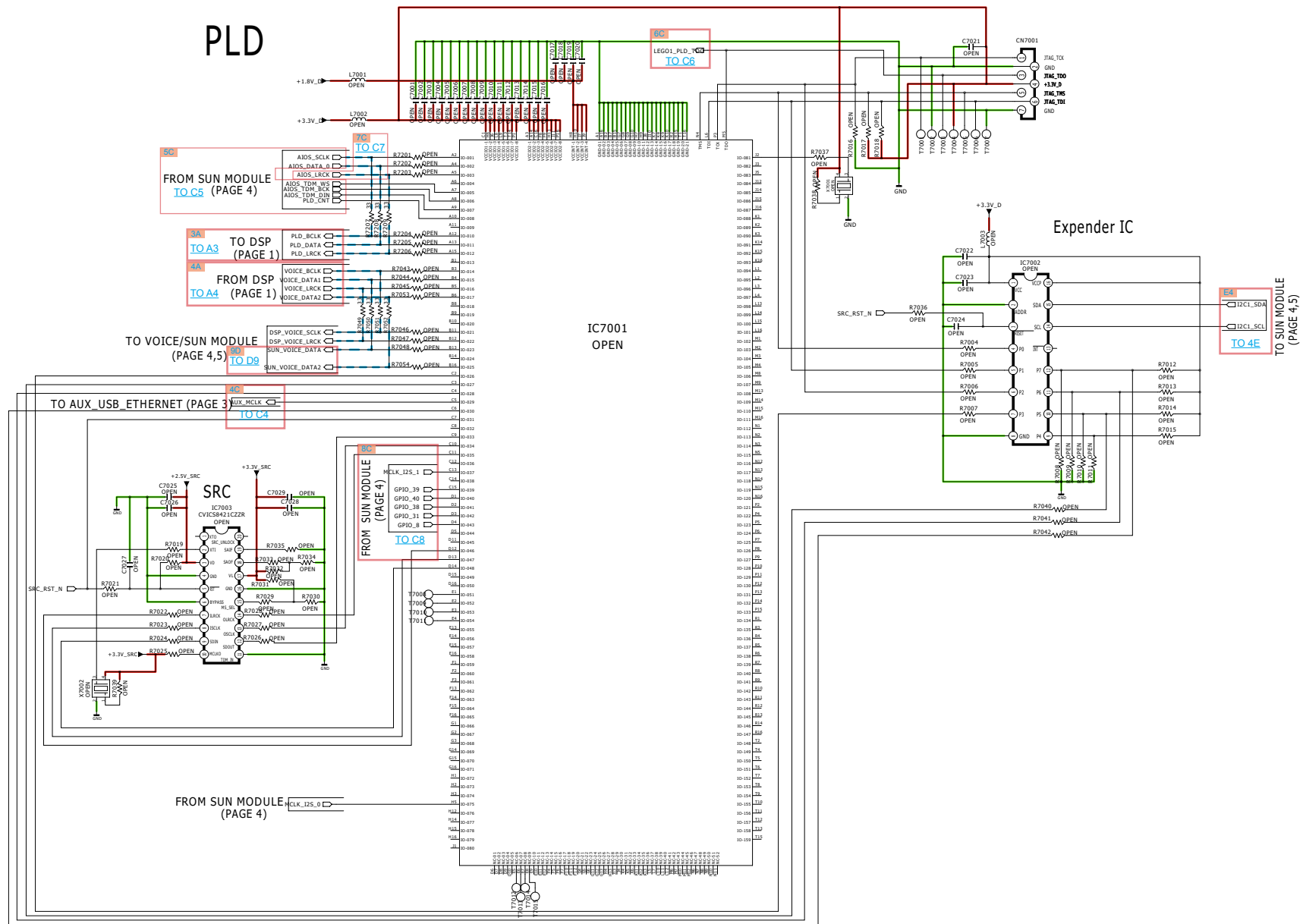

GND LINE POWER+ LINE POWER- LINE ANALOG AUDIO DIGITAL AUDIO STBY POWER

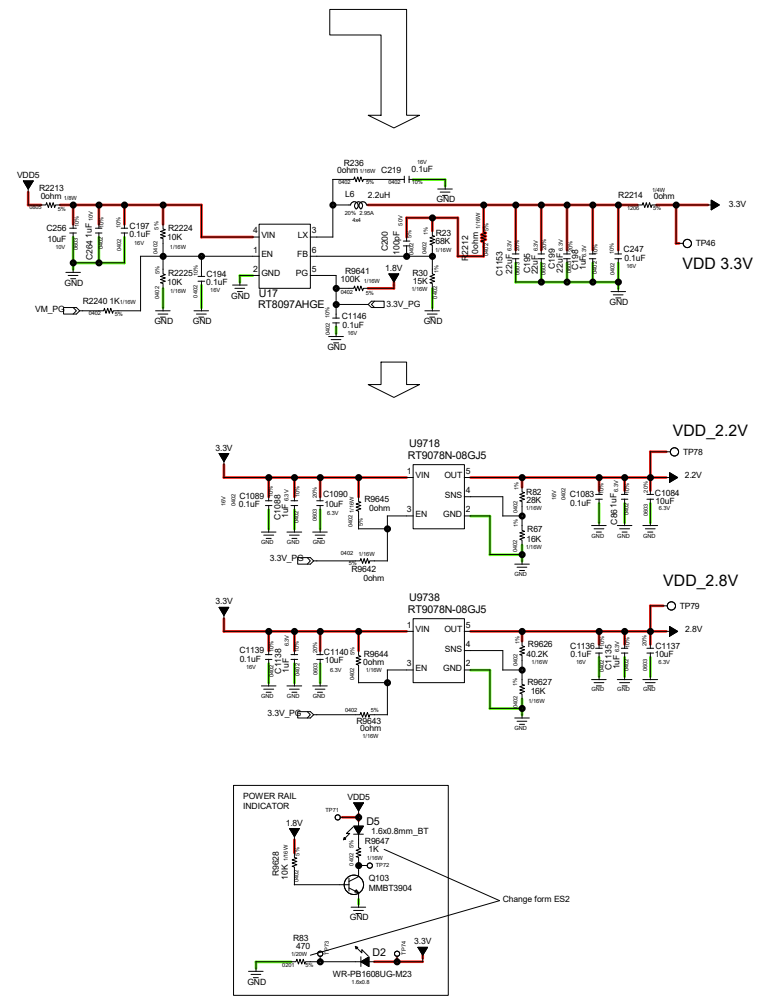
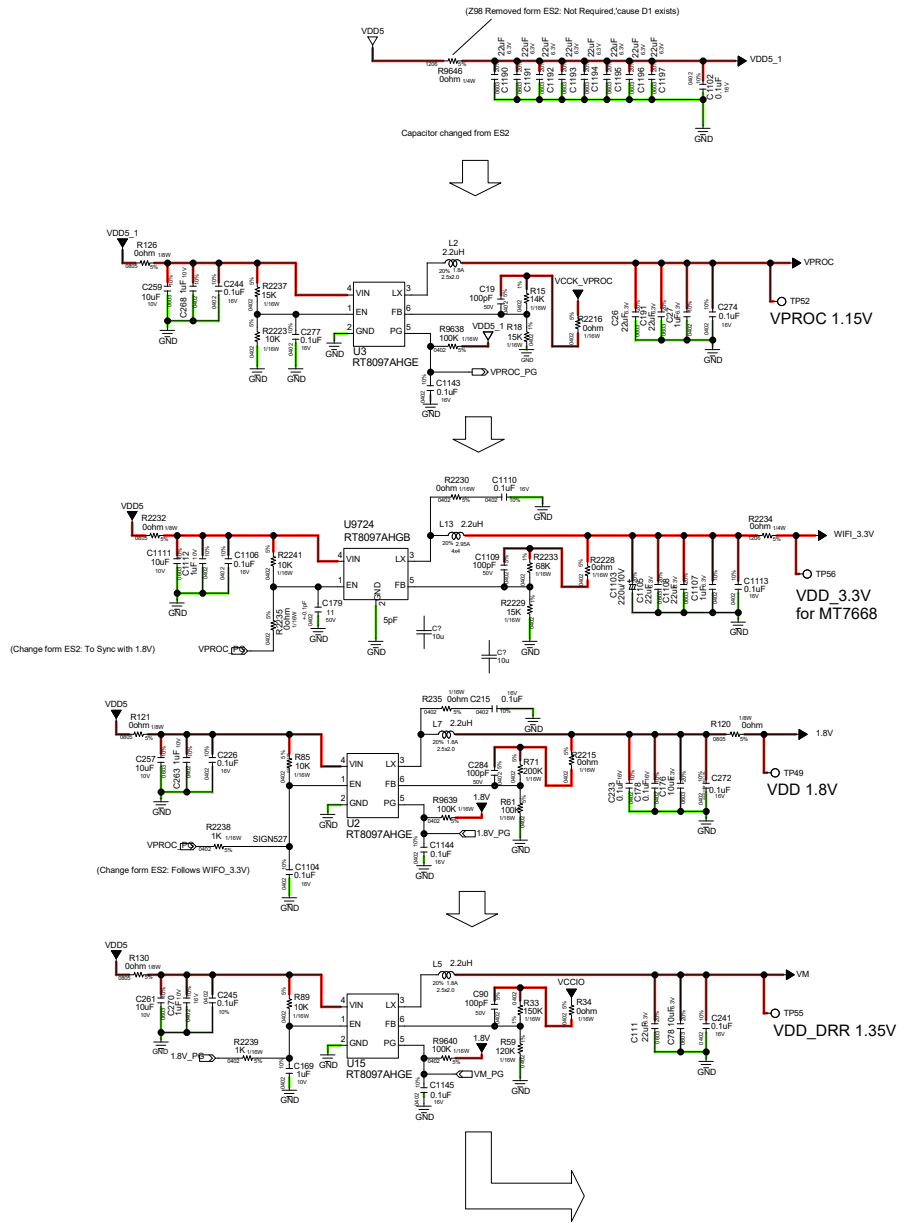

GND LINE POWER+ LINE POWER- LINE ANALOG AUDIO DIGITAL AUDIO STBY POWER

Before Servicing This Unit
 Electrical
 Mechanical
 Repair Information
 Updating

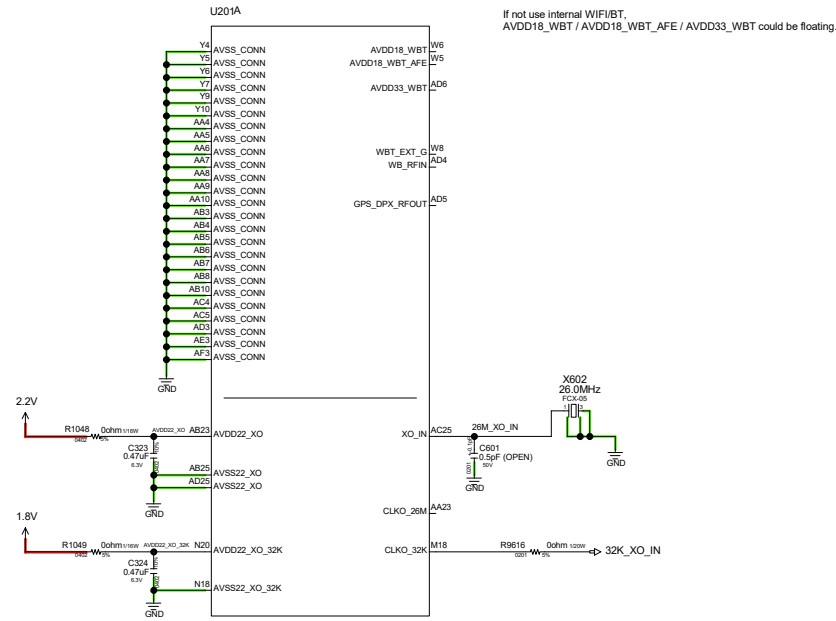

GND LINE POWER+ LINE POWER- LINE ANALOG AUDIO DIGITAL AUDIO STBY POWER

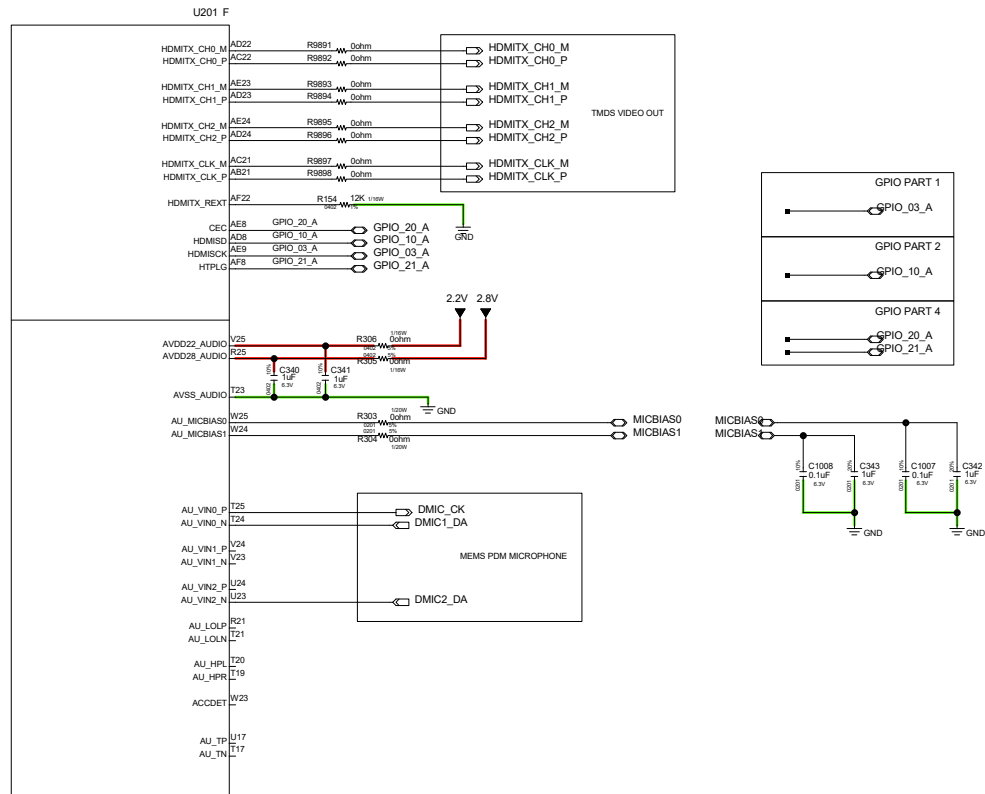

GND LINE POWER+ LINE POWER- LINE ANALOG AUDIO DIGITAL AUDIO STBY POWER

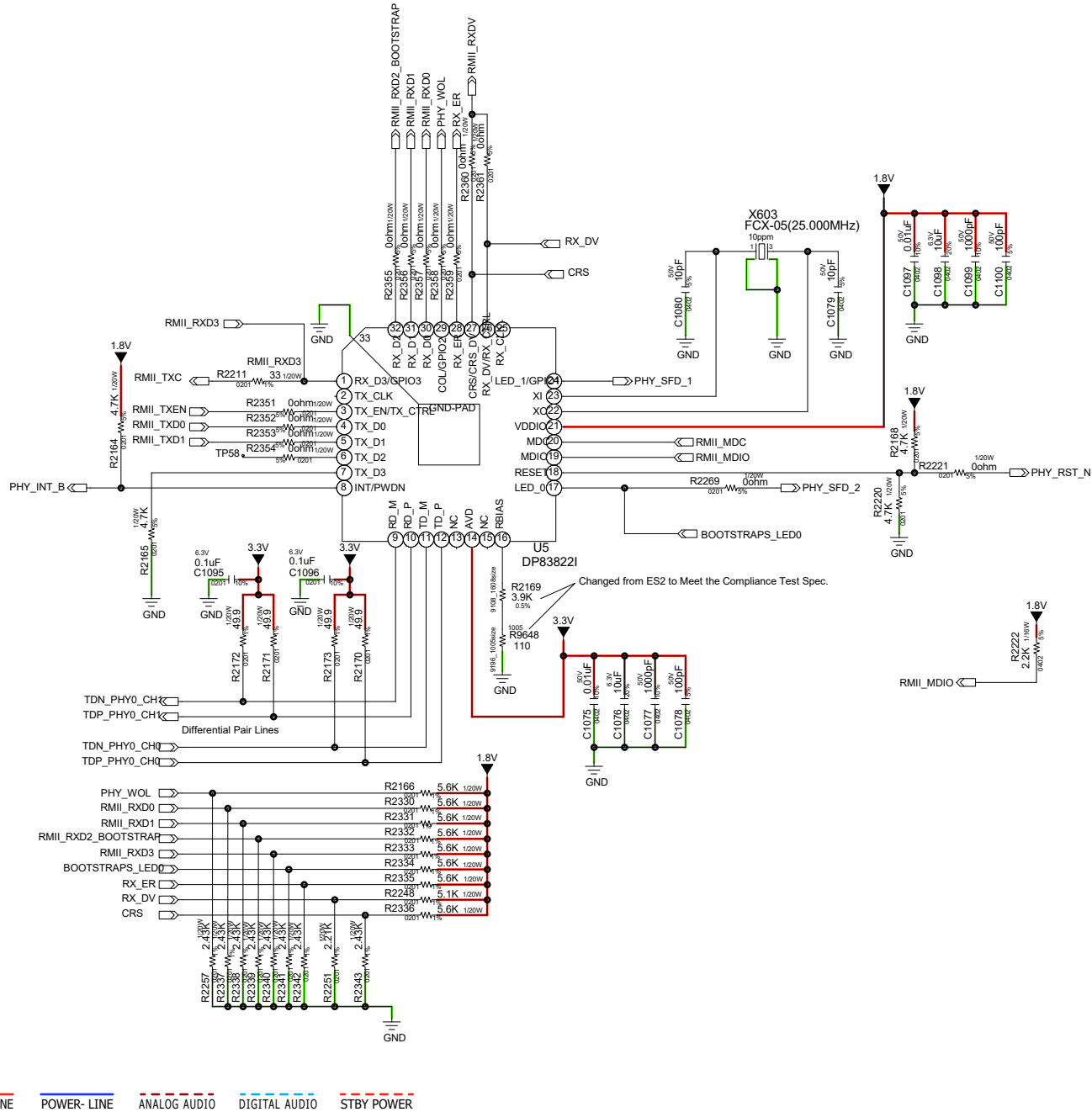

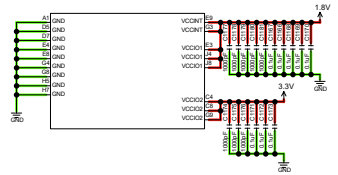
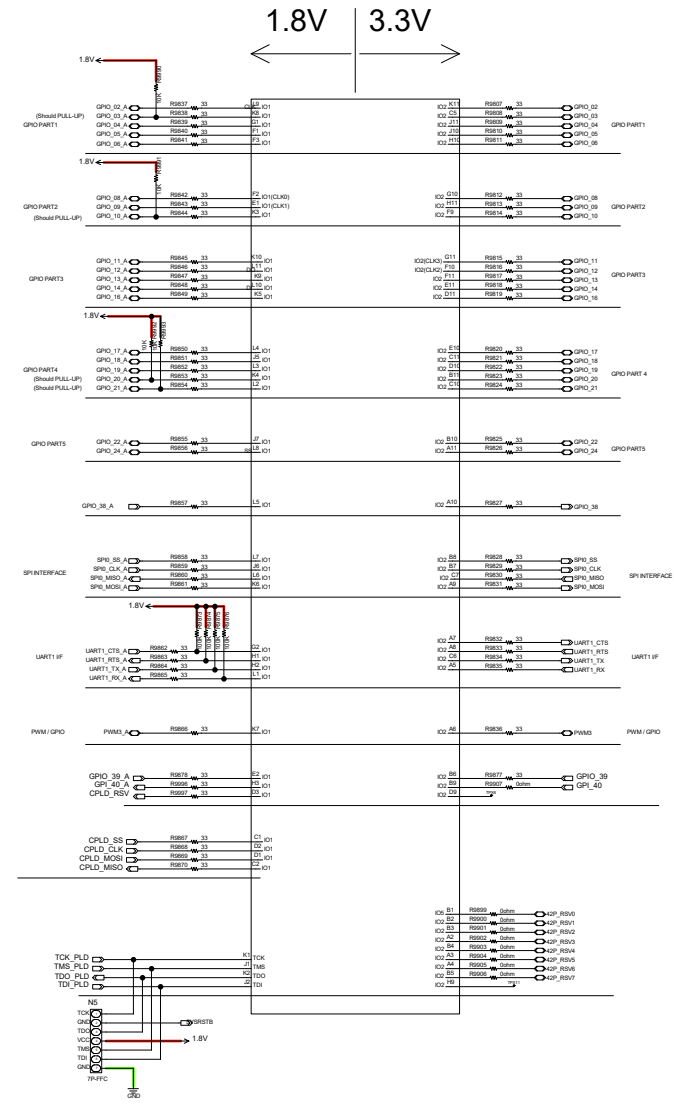

USB-HUB was DELETED
CPLD PART WILL BE
STATED HERE

— GND LINE
 — POWER+ LINE
 — POWER- LINE
 — ANALOG AUDIO
 — DIGITAL AUDIO
 — STBY POWER

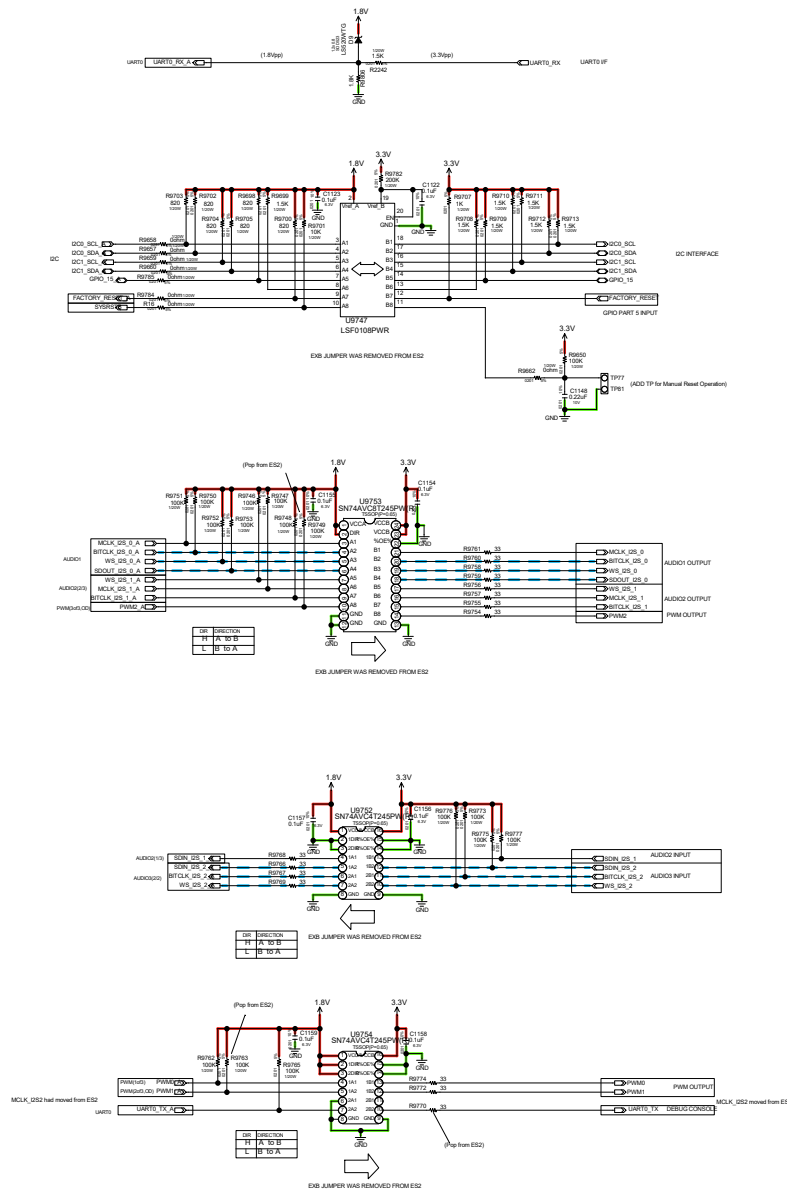

GND LINE POWER+ LINE POWER- LINE ANALOG AUDIO DIGITAL AUDIO STBY POWER

Before Servicing This Unit

Electrical

Mechanical

Repair Information

Updating

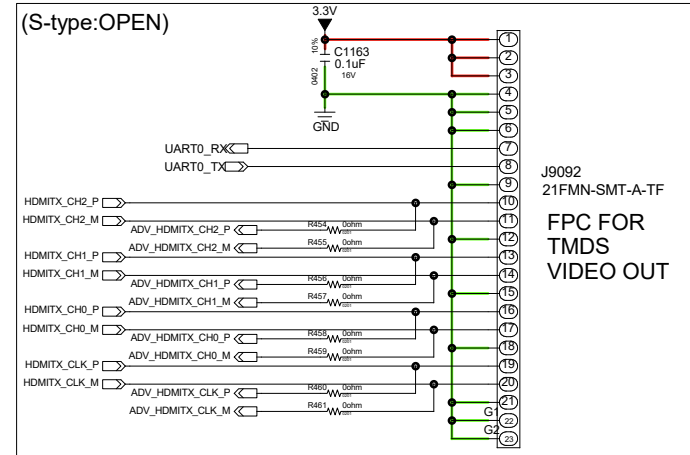
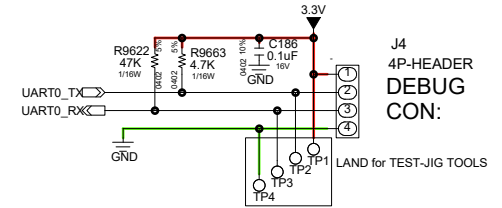
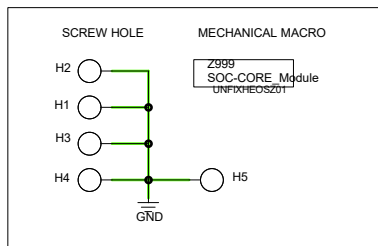
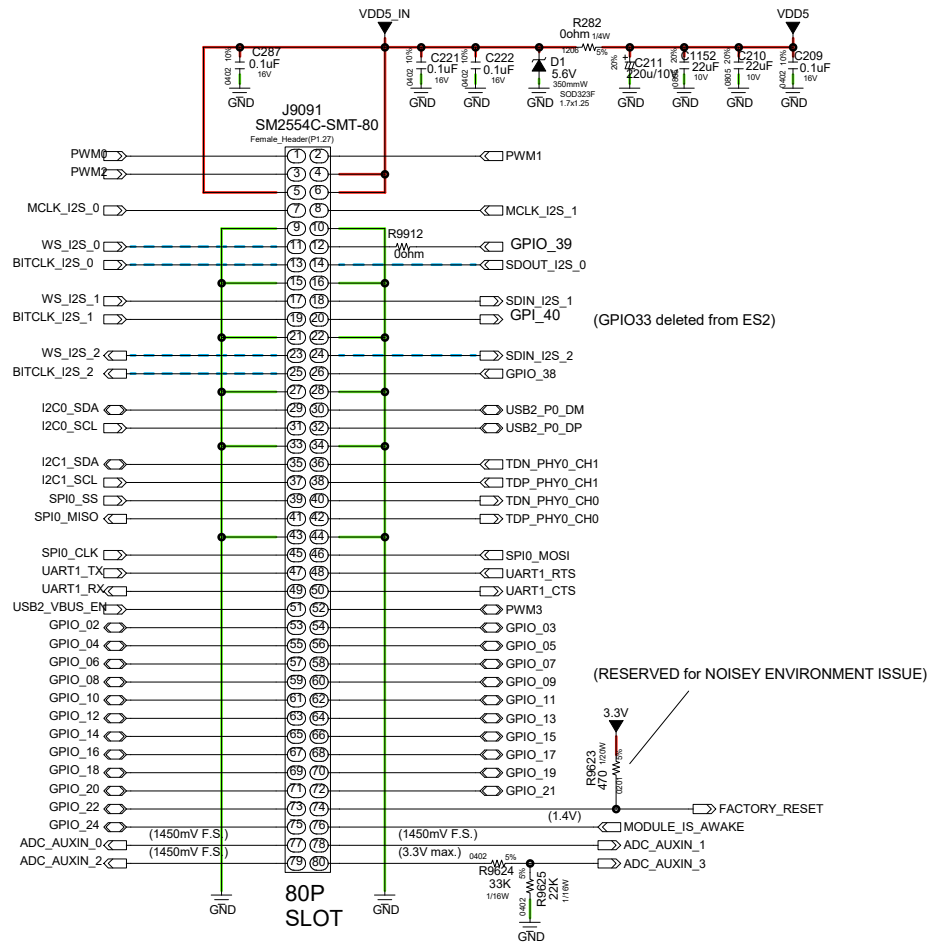

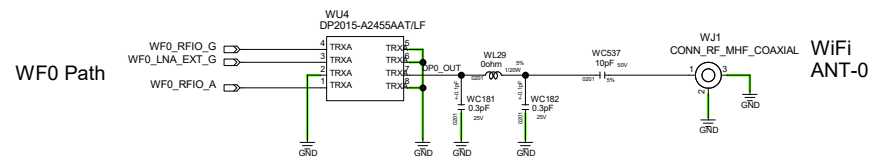
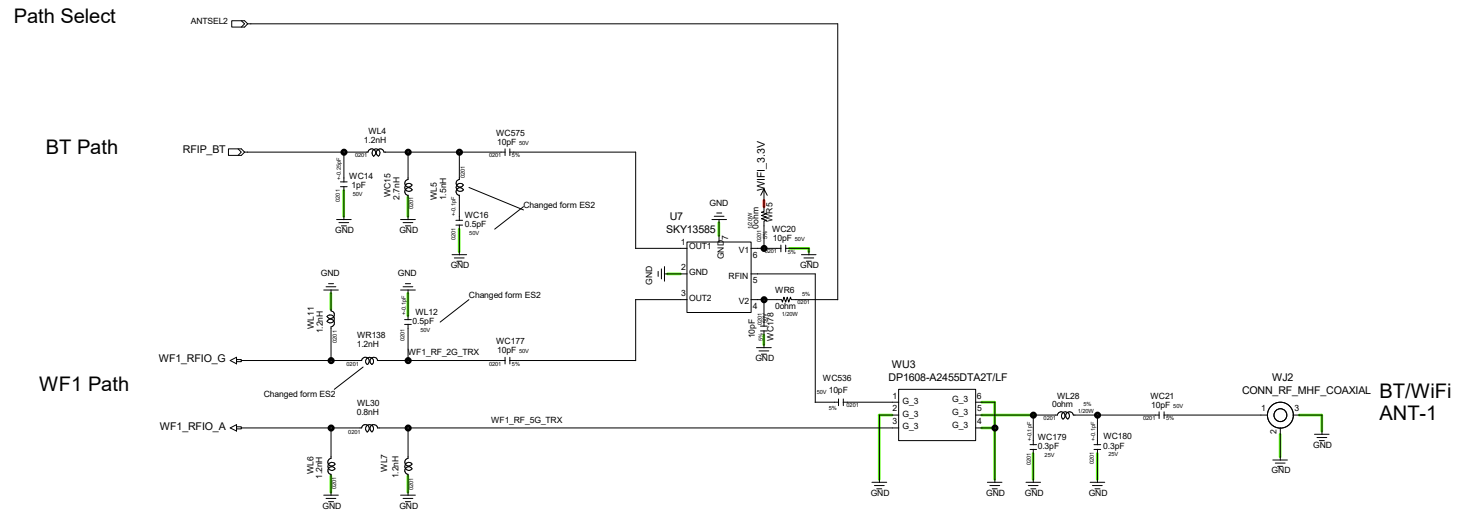

GND LINE POWER+ LINE POWER- LINE ANALOG AUDIO DIGITAL AUDIO STBY POWER

Before Servicing This Unit
 Electrical
 Mechanical
 Repair Information
 Updating

(S-type:OPEN)

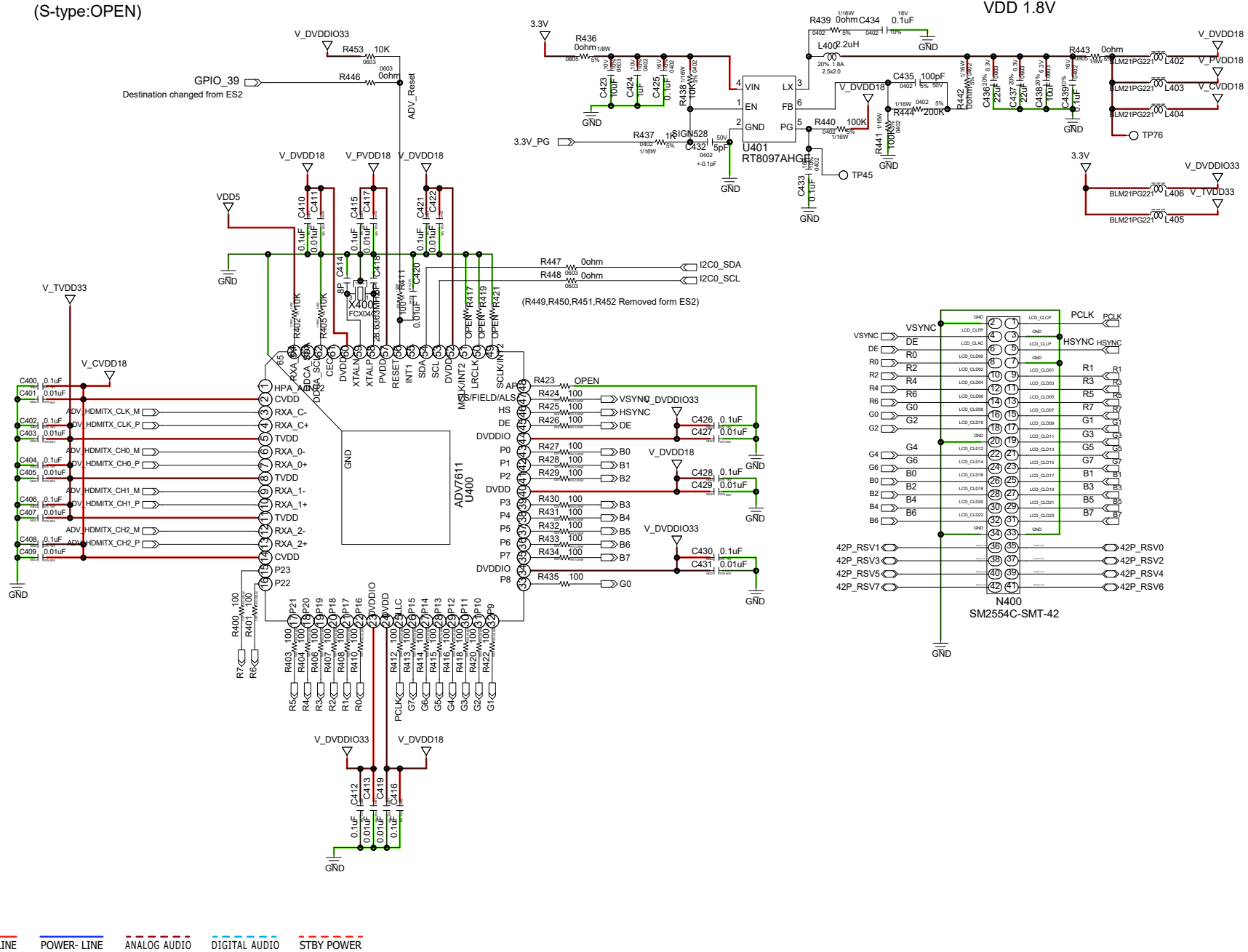

GND LINE POWER+ LINE POWER- LINE ANALOG AUDIO DIGITAL AUDIO STBY POWER

GND LINE POWER+ LINE POWER- LINE ANALOG AUDIO DIGITAL AUDIO STBY POWER

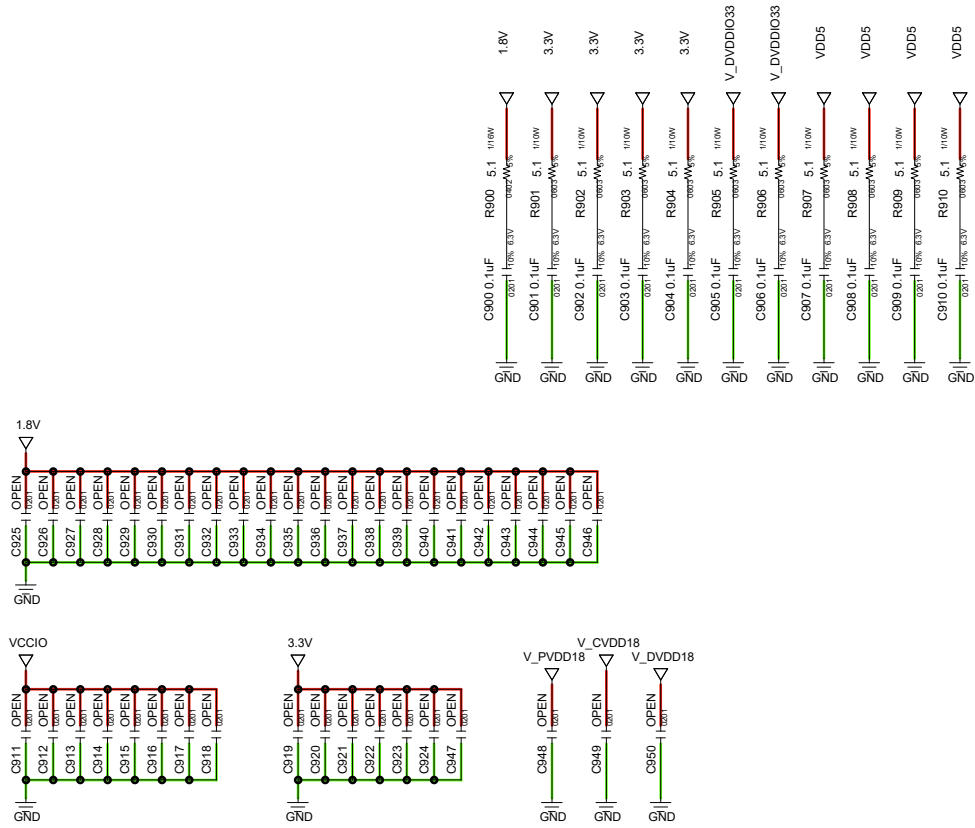

PRINTED CIRCUIT BOARDS

TOUCH, MAIN, SMPS, LED, SUN MODULE

Lead-free Solder
When soldering, use the Lead-free Solder (Sn-Ag-Cu).

TOUCH (A side)

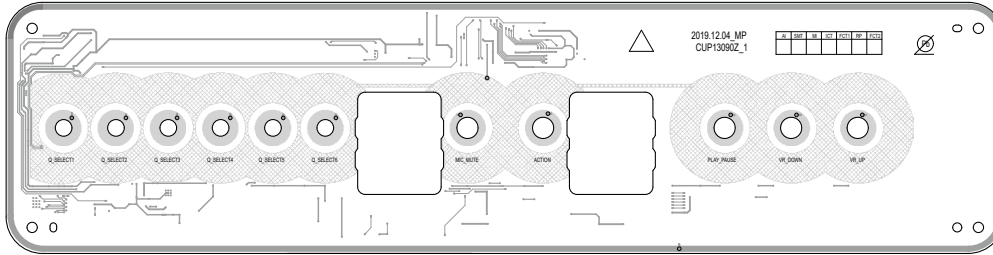

TOUCH (B side)

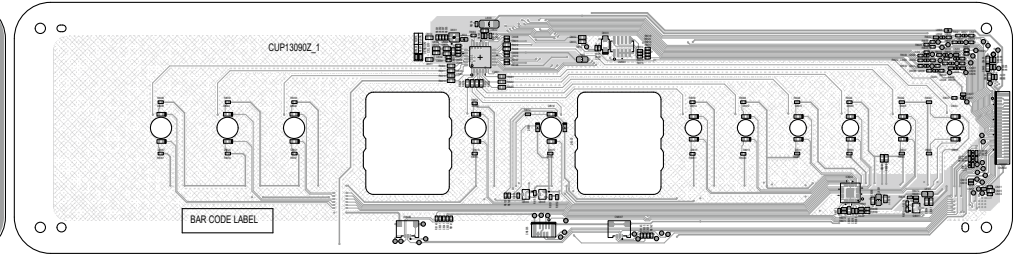

MAIN (A side)

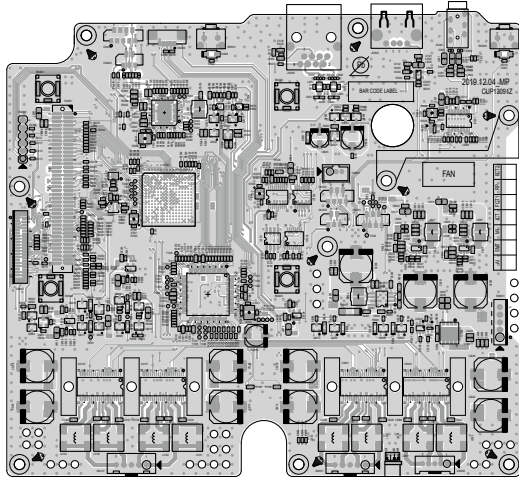

MAIN (B side)

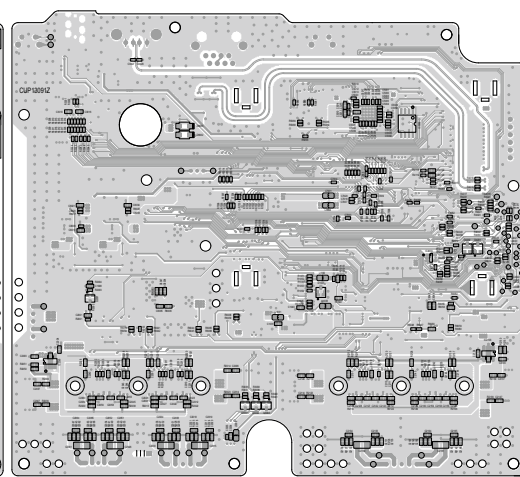

SMPS (A side)

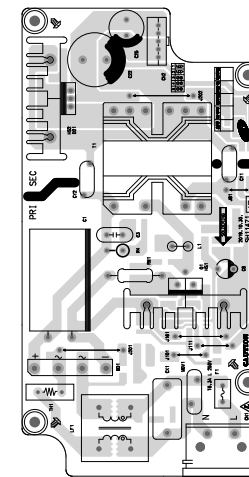

SMPS (B side)

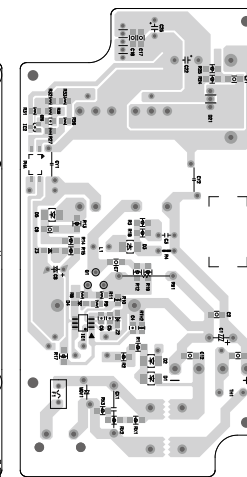

LED (A side)



LED (B side)



SUN MODULE (A side)

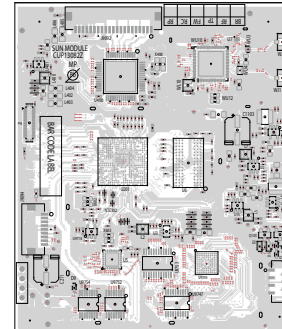

SUN MODULE (B side)

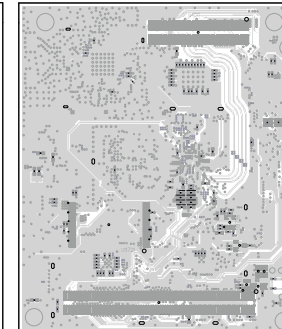

Before Servicing
This Unit

Electrical

Mechanical

Repair Information

Updating

DENONHOME350 BLOCK DIAGRAM

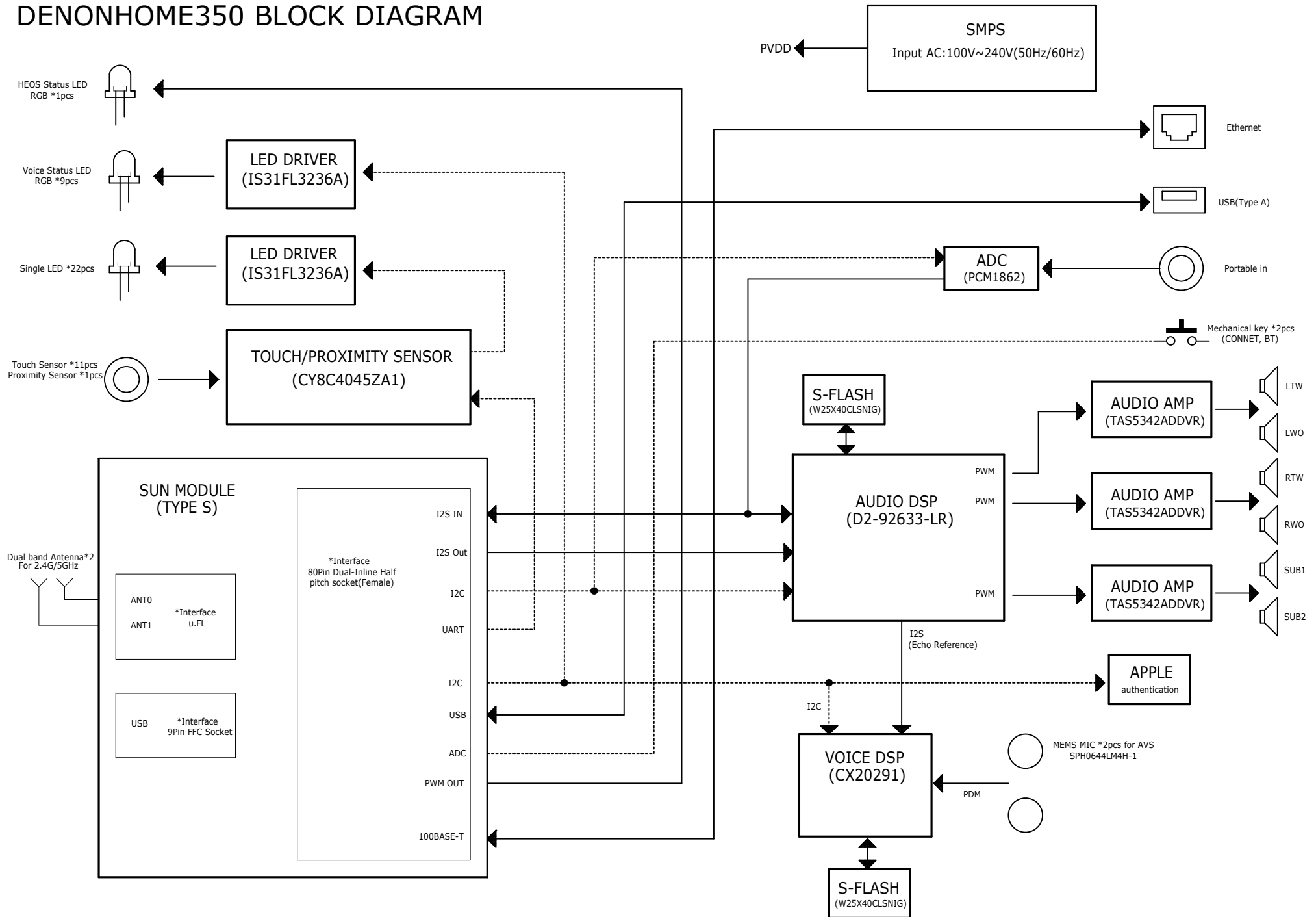

Before Servicing This Unit

Electrical

Mechanical

Repair Information

Updating

DENON HOME350

Power DIAGRAM

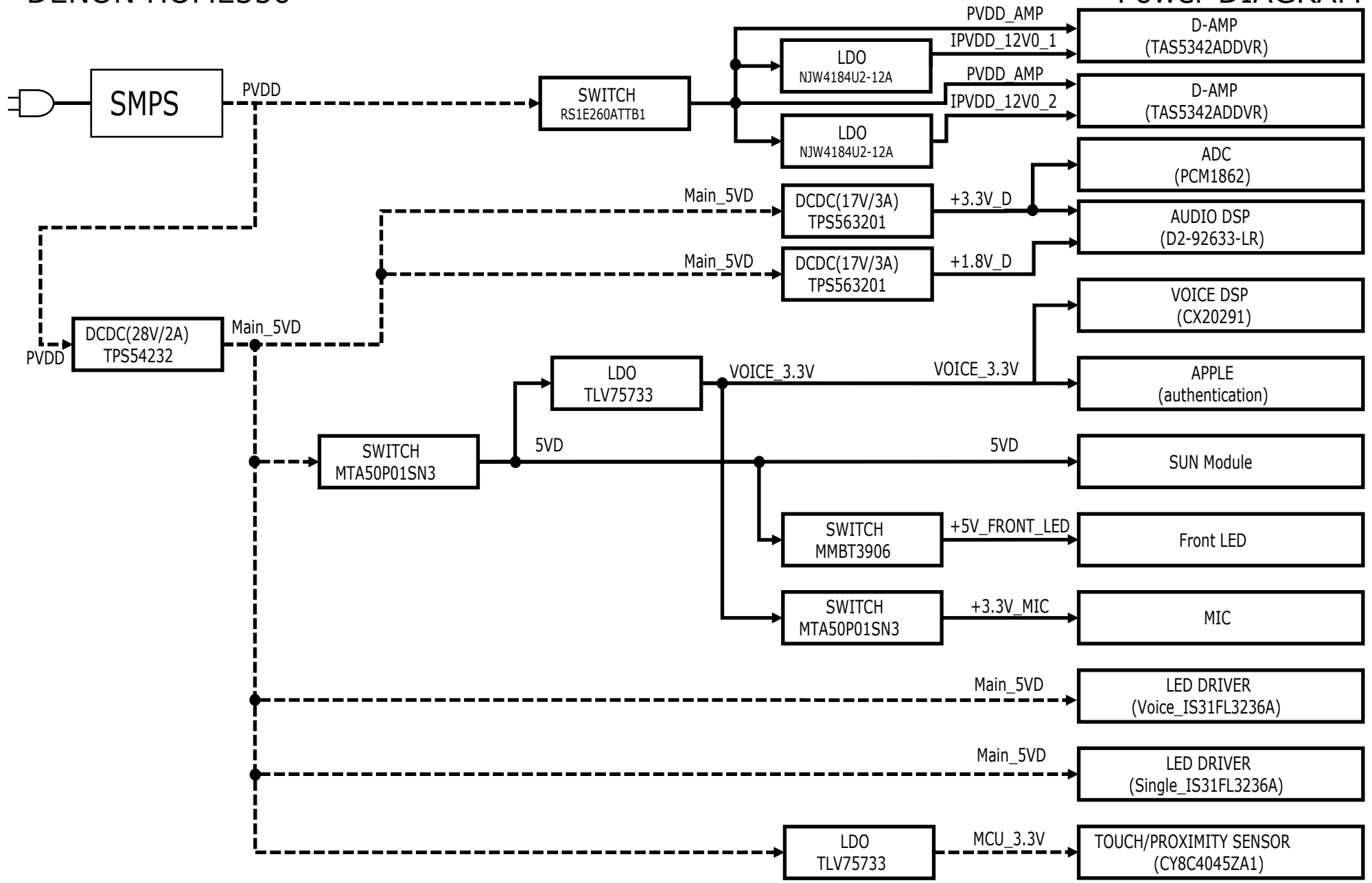

- Before Servicing This Unit
- Electrical
- Mechanical
- Repair Information
- Updating

DENONHOME350 WIRING DIAGRAM

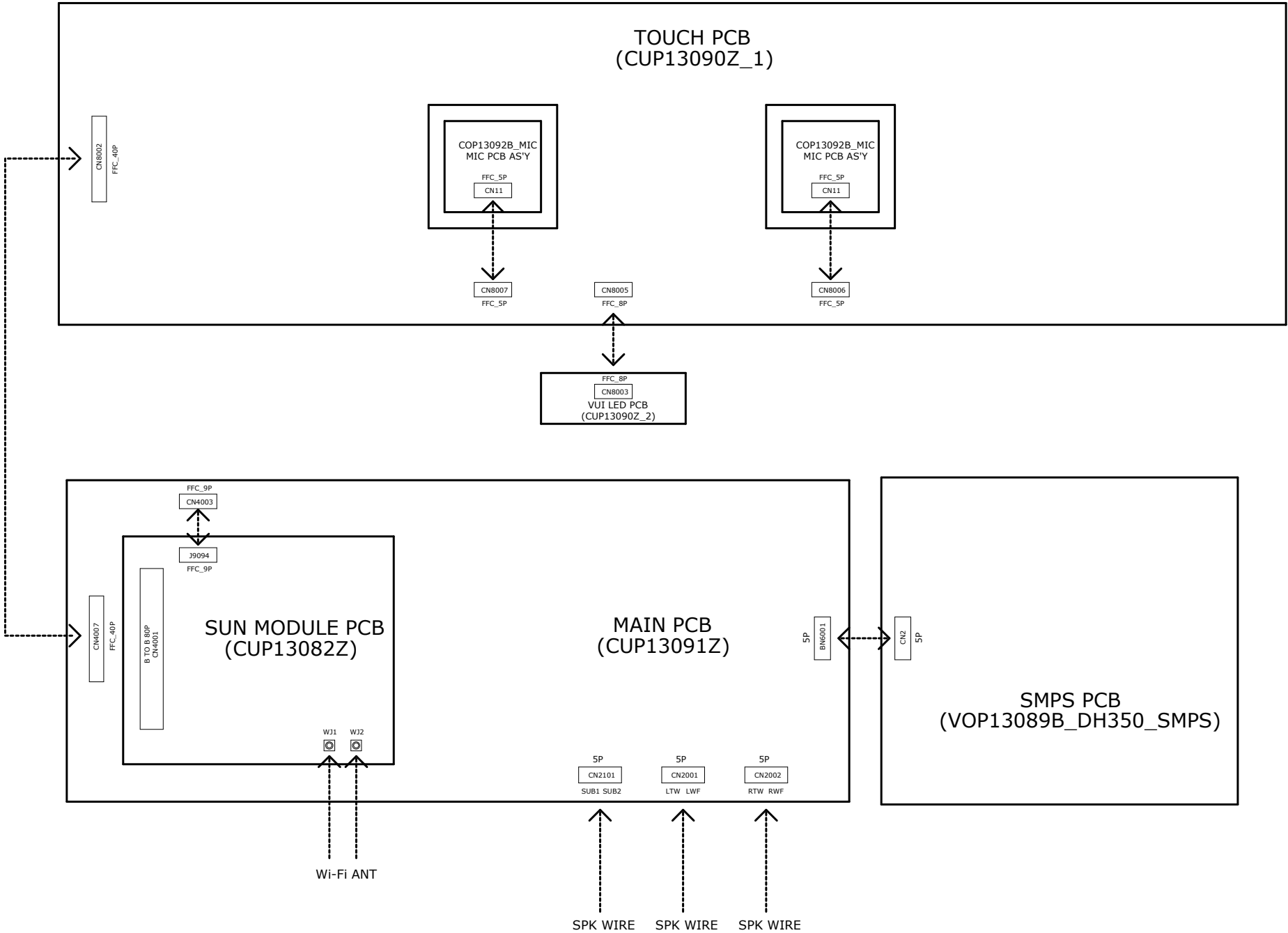

SEMICONDUCTORS

Only major semiconductors are shown, general semiconductors etc. are omitted to list.
The semiconductor which described a detailed drawing in a schematic diagram are omitted to list.

1. IC's

D2-92633-LR (IC1001)

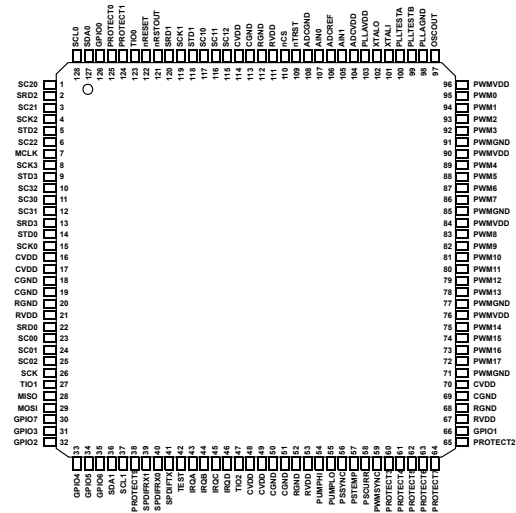

Block Diagram

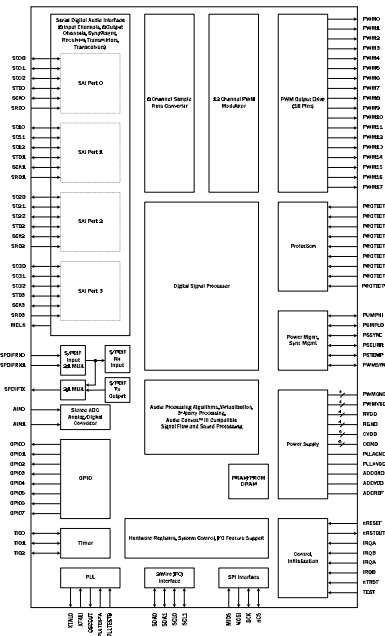

CX20921-21Z (IC5001)

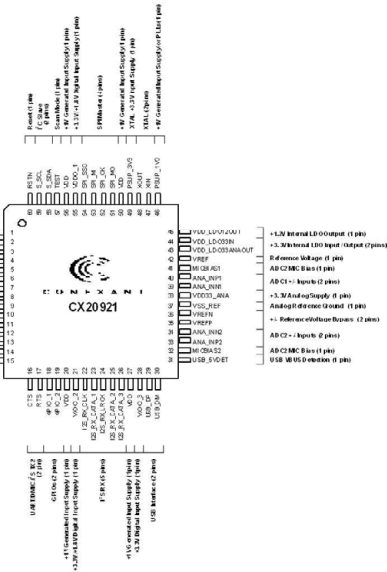

Block Diagram

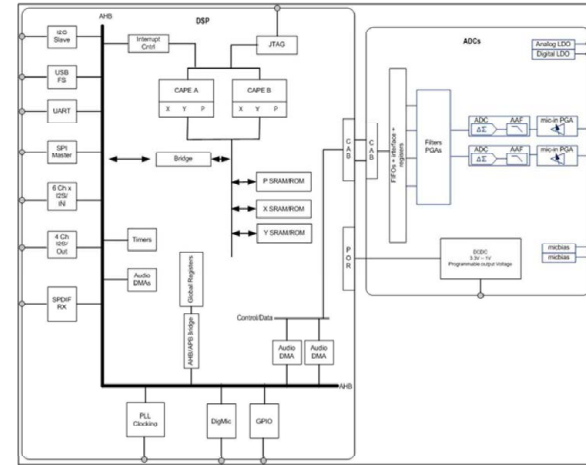

Before Servicing This Unit

Electrical

Mechanical

Repair Information

Updating

CY8C4045AZI-S413 (IC8001)

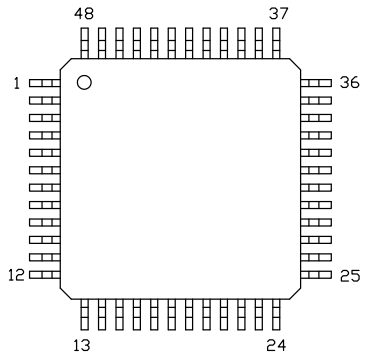

Block Diagram

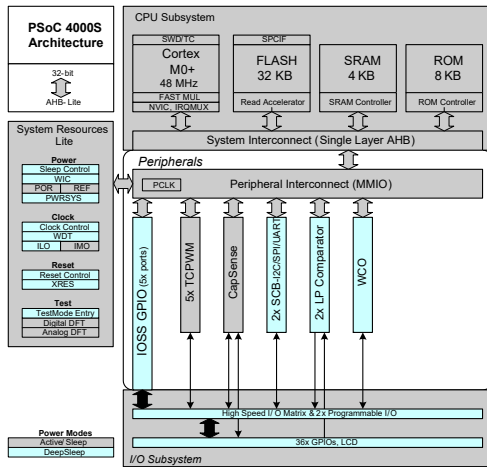

DISASSEMBLY

Flowchart

1. Grille
2. TOP ASSY
3. BOTTOM ASSY
4. FRONT ASSY

EXPLODED VIEW

SEALING GASKET VIEW OF AN AIR LEAK PREVENTION

PACKAGING VIEW

Flowchart

- Remove each part following the flow below.
- Reassemble the removed parts in the reverse order.
- Read "[SAFETY PRECAUTIONS](#)" before reassembling the removed parts.
- If wire bundles are removed or moved during adjustment or part replacement, reshape the wires after completing the work. Failure to shape the wires correctly may cause problems such as noise.
- See "[EXPLODED VIEW](#)"

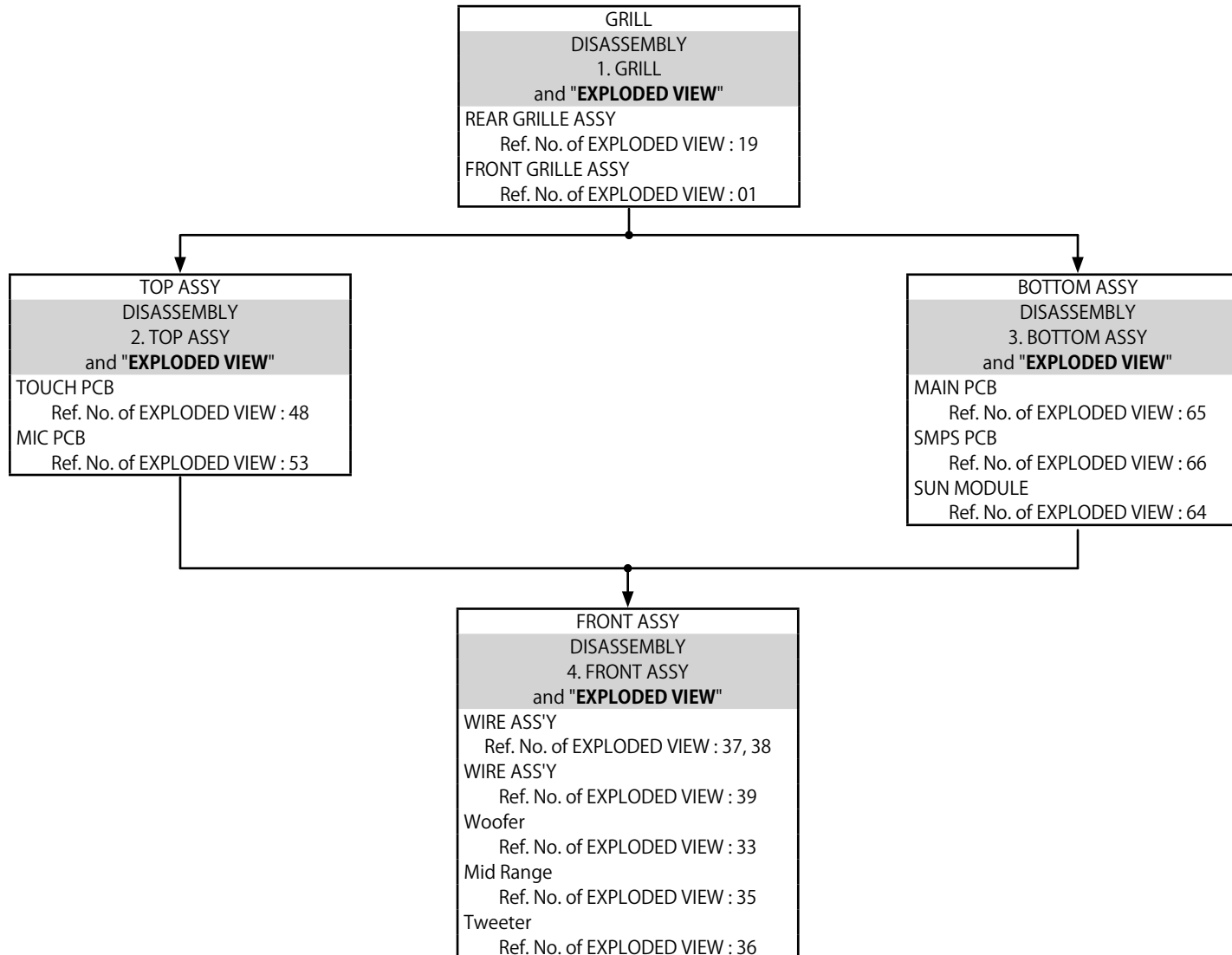

Explanatory Photos for DISASSEMBLY

- For the shooting direction of each photos used in this manual, see the photo below.
- **A, B, C and D** in the photo below indicate the shooting directions of photos.
- The photographs with no shooting direction indicated were taken from the top of the unit.
- Photos of DENON HOME 350 are used in this manual.

The viewpoint of each photograph

(Shooting direction : X) [View from the top]

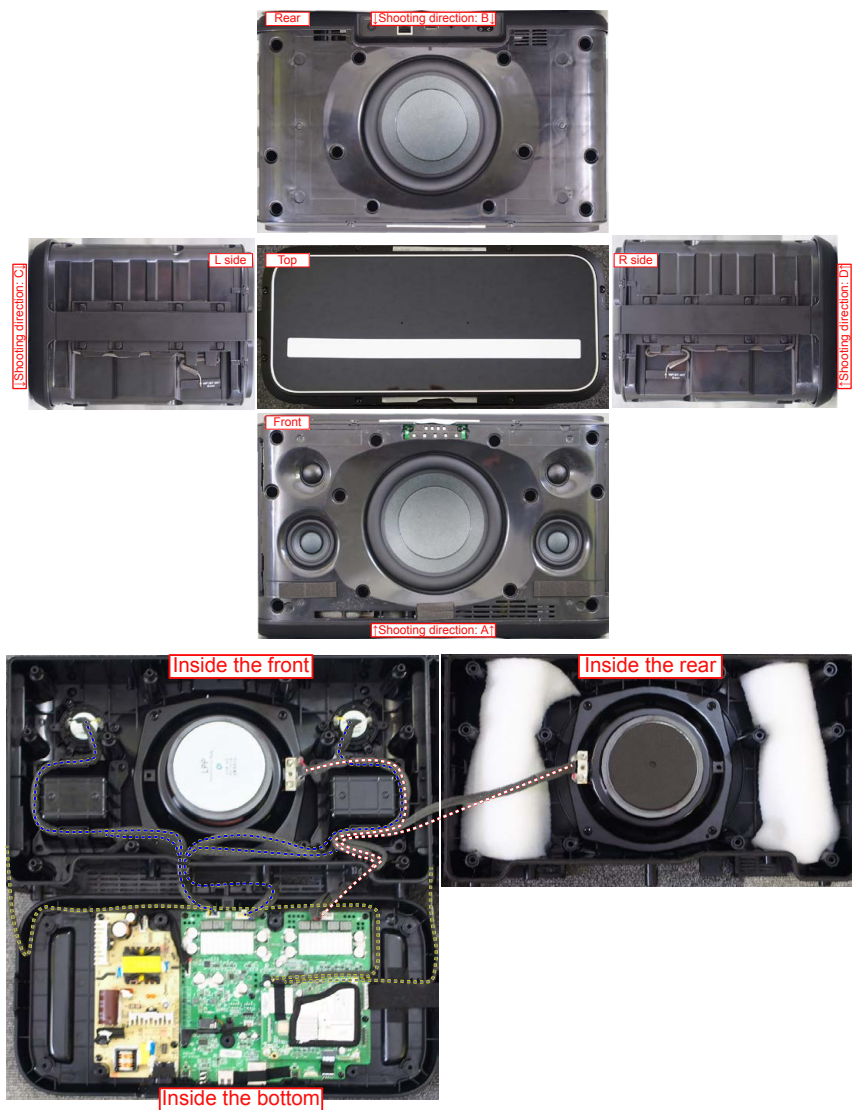

1. Grille

Proceeding : **Grille**

- (1) Remove the Grille.



2. TOP ASSY

Proceeding : **Grille** → **TOP ASSY**

- (1) Remove the screws.

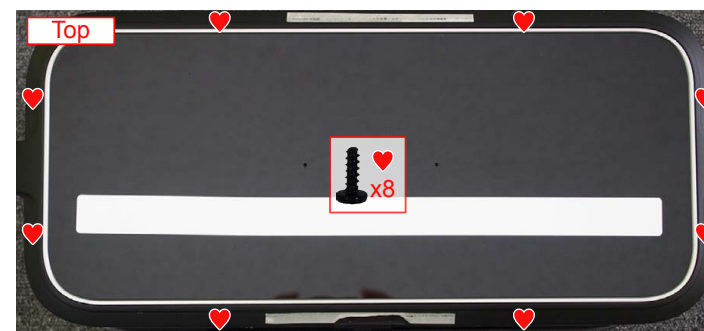

- (2) Remove the FFC.

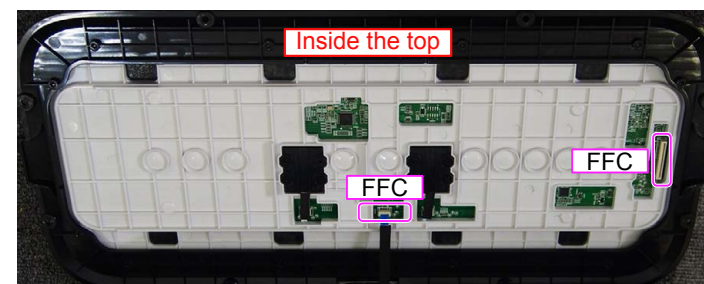

3. BOTTOM ASSY

Proceeding : **Grille** → **BOTTOM ASSY**

(1) Remove the SIDE PLATE. Remove the FFC. Remove the ANT wire.

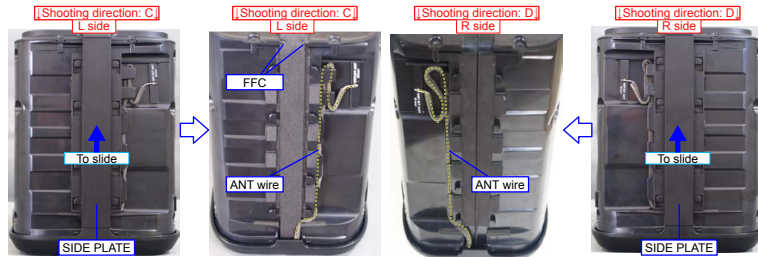

(2) Remove the Foot. Remove the Sheet. Remove the screws.
NOTE : Do not reuse Foot and SHEET after disassembly.

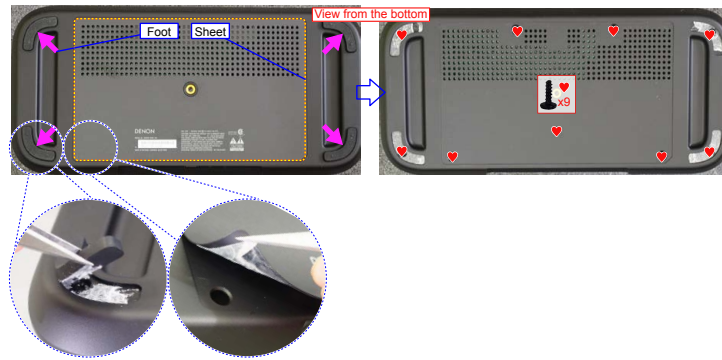

(3) Remove the screws. Remove the connector. Remove the FFC. Remove the ANT.

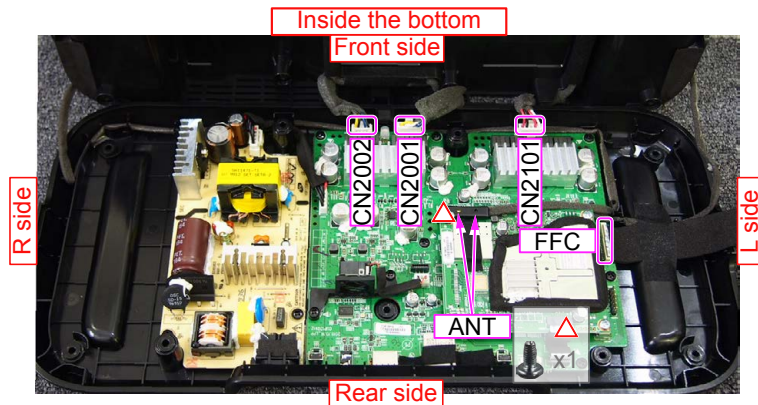

4. FRONT ASSY

Proceeding : **Grille** → **TOP ASSY** → **BOTTOM ASSY** → **FRONT ASSY**

(1) CUSHION をカットします。 Remove the screws.

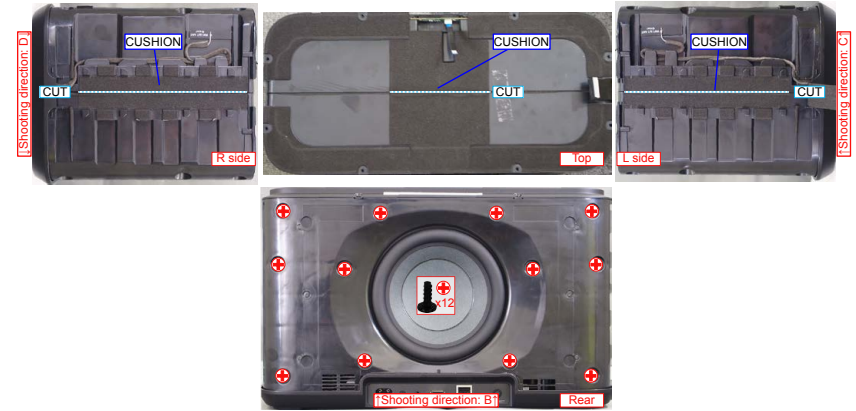

(2) Be sure to shape wires correctly during assembly.

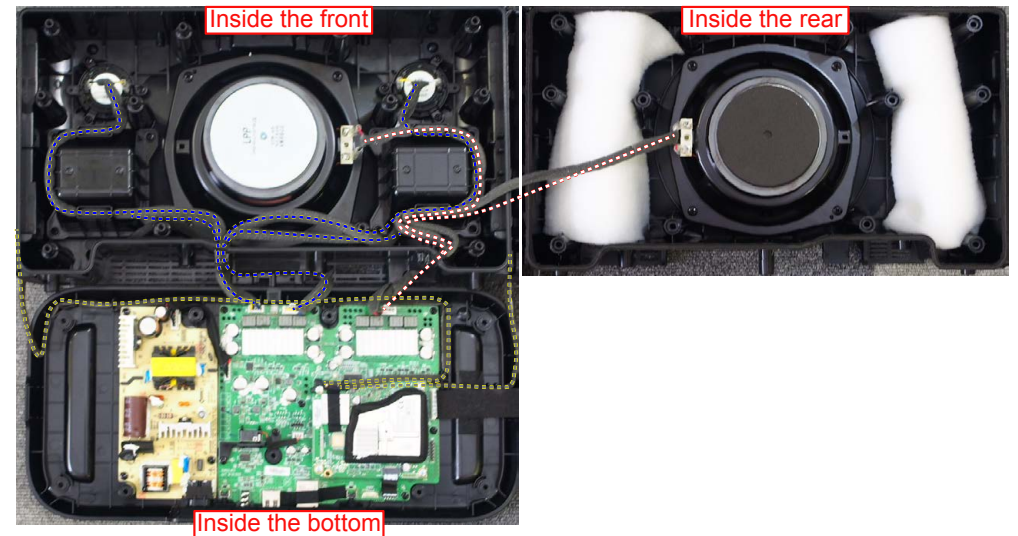

EXPLODED VIEW

Parts List : <https://dmedia.soundunited.com/documents/details/26501>

A : DENON HOME 350 TOP ASSY : 16, 45, 46, 47, 48, 49, 50, 51, 52, 53, 54, 55, S1, S6, S7
 B : DENON HOME 350 BOTTOM ASSY : 06, 57, 58, 59, 75

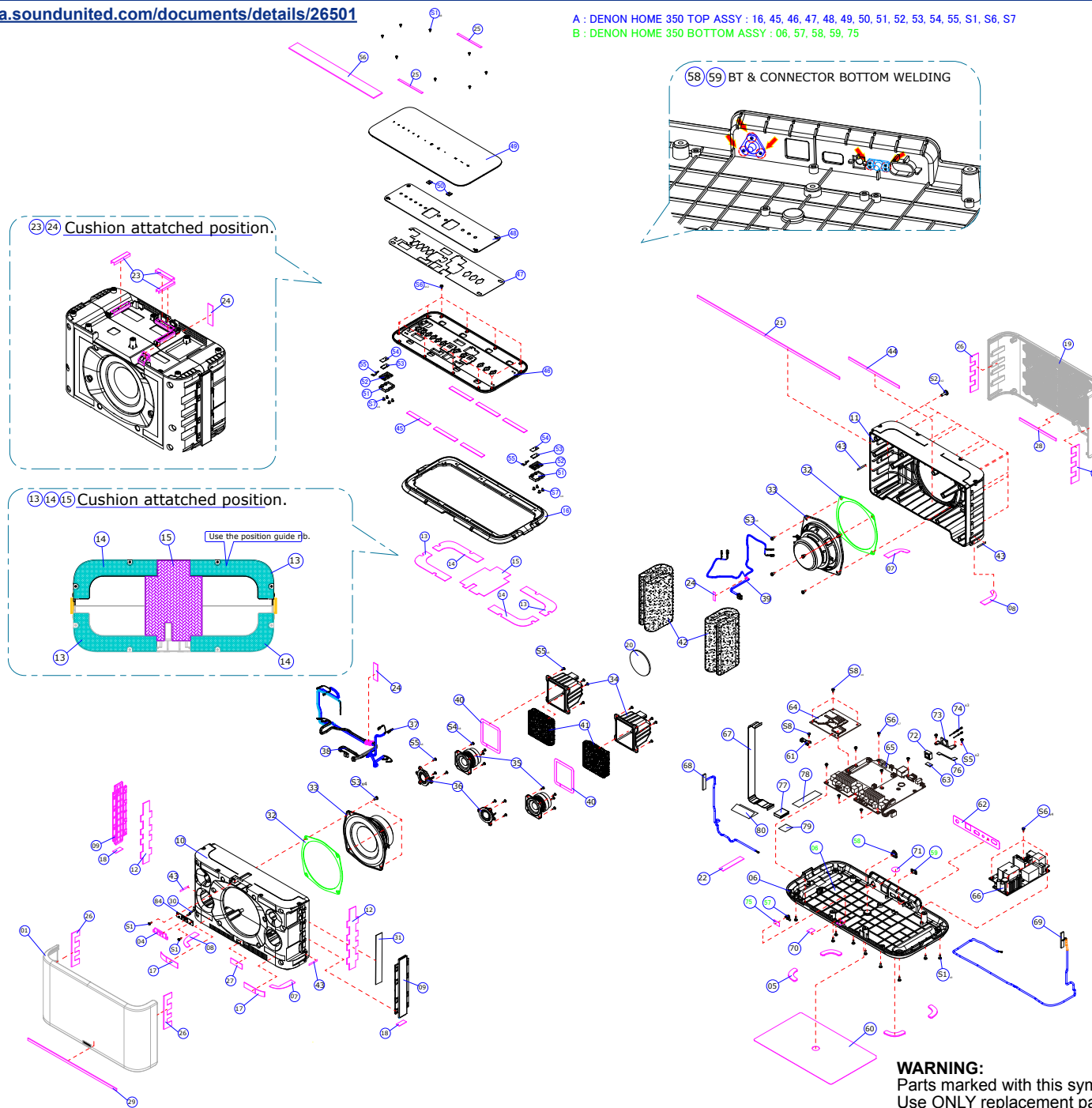

WARNING:
 Parts marked with this symbol \triangle have critical characteristics.
 Use ONLY replacement parts recommended by the manufacturer.

Before Servicing
 This Unit

Electrical

Mechanical

Repair Information

Updating

SEALING GASKET VIEW OF AN AIR LEAK PREVENTION

Parts List : <https://dmedia.soundunited.com/documents/details/26501>

PREPARE ASS'Y CUSHION

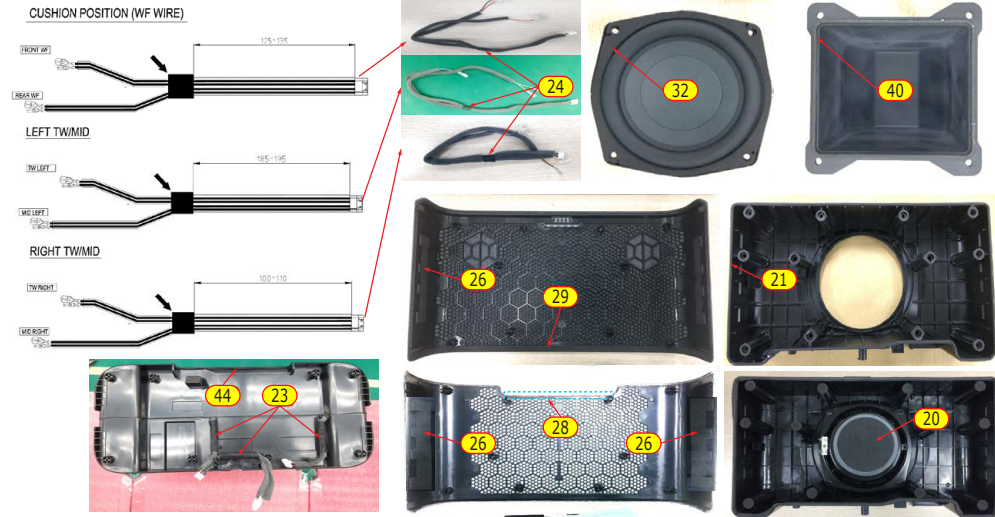

BOTTOM & TOP ASS'Y CUSHION

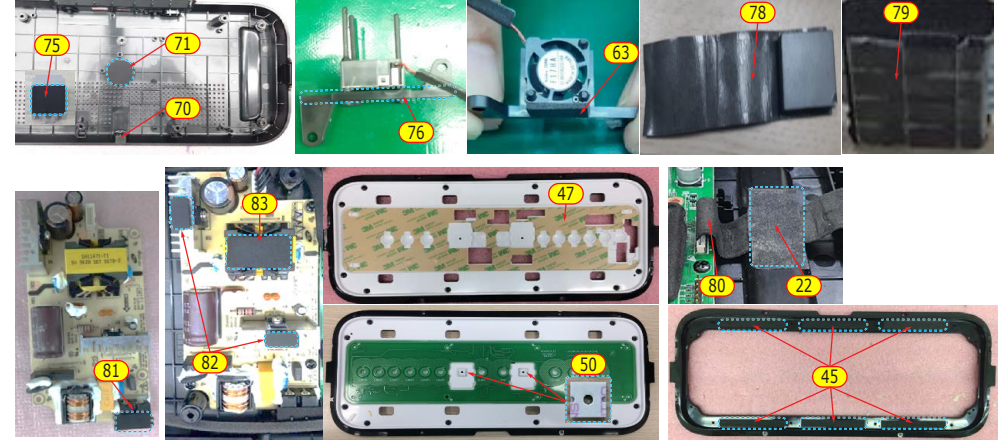

MAIN ASS'Y CUSHION

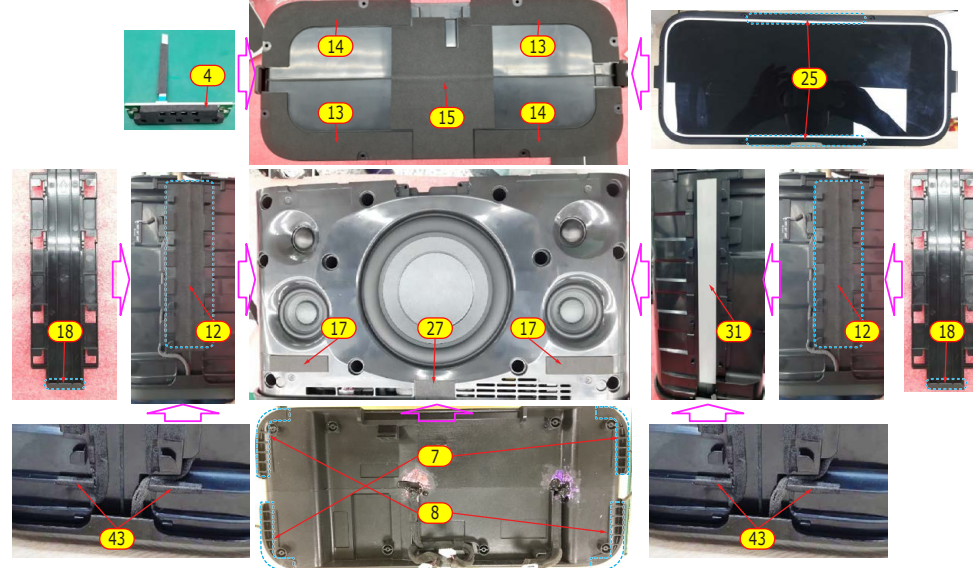

No.	Part No.	Part Name	Remarks	Q'ty
A-45	-	CUSHION TOP COVER 75X10X1.0T		VHS1A897 6
A-47	-	TAPE TOUCH PCB		VHS1A896 1
A-50	-	MIC CUSHION		VHS1A844 2
B-75	-	STATUS TAPE		VHS1A952 1
07	943471102130S	CUSHION MAIN BODY BOTTOM R		VHS1A912 2
08	943471102140S	CUSHION MAIN BODY BOTTOM L		VHS1A905 2
12	943471102150S	CUSHION BOTH SIDE,EVA0.5T,DH350,160X5MM		VHS1A939 2
13	943471102160S	CUSHION MAIN BODY TOP L		VHS1A902 2
14	943471102170S	CUSHION MAIN BODY TOP R		VHS1A903 2
15	943471102180S	CUSHION MAIN TOP CENTER		VHS1A904 1
17	943471102190S	PE FOAM CUSHION-02		VHS1A909 2
18	943471102200S	SIDE COVER CUSHION		VHS1A979 2
20	943471102210S	CUSHION MAGNET WF		VHS1A907 1
21	943471102220S	CUSHION MAIN BODY SEALING(1135X8X0.5T)		VHS1A901 1
22	943471102230S	FELT TAPE WIRE INNER,50X9X0.3T		VHS1A940 1
23	943471102240S	FELT TAPE WIRE		VHS1A911 3
24	943471102250S	CUSHION MAIN FRONT		VHS1A906 3
25	943471101830S	DOUBLE SIDE TAPE		VHS1A919 2
26	943471102260S	GRILLE CUSHION		VHS1A968 4
27	943471102270S	FRONT HOUSING CUSHION		VHS1A980 1
28	943471102280S	GRILLE CUSHION 2		VHS1A982 1
29	943471102290S	GRILLE CUSHION 1		VHS1A981 1
31	943471102300S	FFC CABLE TAPE		VHS1A990 1
32	943471102310S	CUSHION WOOFER		VHS1A898 2
40	943471102320S	CUSHION MID COVER SEALING(280X7X0.5T)		VHS1A899 2
43	943471102330S	SIDE COVER CUSHION 1		VHS1A983 4
44	943471102340S	REAR HOUSING CUSHION		VHS1A967 1
63	943544105510S	FAN CUSHION		VHS1A978 1
70	943471101920S	STATUS CUSHION		VHS1A922 1
71	943471102360S	CUSHION BOTTOM(INsert NUT)		VHS1A913 1
76	943471102370S	FAN BRACKET CUSHION		VHS1A986 1
78	943471102380S	FERRITE CORE CUSHION		VHS1A987 1
79	943471102390S	FERRITE CORE TAPE		VHS1A988 1
80	943471102400S	FFC CABLE CUSHION		VHS1A989 1
81	943471102420S	SMPs CUSHION		VHS1A991 1
82	943471102090S	RUBBER SMPs		CHG1A754 2
83	943471102410S	TRANS CUSHION		VHS1A992 1

Before Servicing
This Unit

Electrical

Mechanical

Repair Information

Updating

PACKAGING VIEW

Parts List : <https://dmedia.soundunited.com/documents/details/26501>

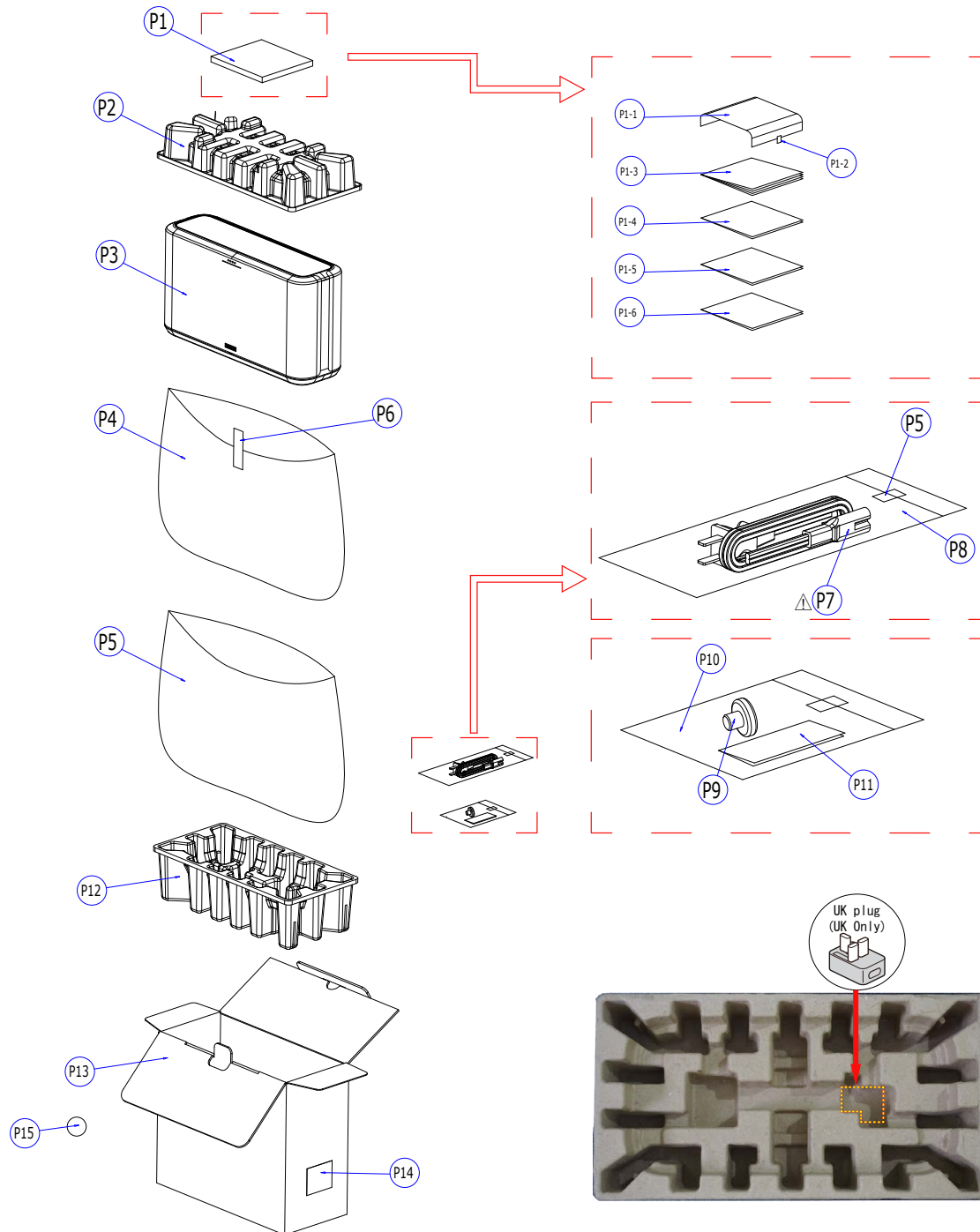

Before Servicing
This Unit

Electrical

Mechanical

Repair Information

Updating

TROUBLE SHOOTING

1. The unit does not power on
2. No sound from the output speakers
3. No sound is output when using the AUX function
4. Cannot connect to the network by wired LAN
5. Cannot connect to the network by wireless LAN
6. USB flash drive not recognized

SPECIAL MODE

Special mode setting button

1. Factory Initialization Mode
2. User Initialization Mode
3. How to check the firmware version, service region settings and service release type
4. Service region settings update procedures
5. Service Release Type settings update procedures

LED STATUS

1. Updating
2. Updating (Service region settings)
3. Updating (Service Release Type)
4. On startup of HEOS (when power is turned on)
5. Factory Reset
6. Software Reset (Clear user settings)
7. Critical Error
8. When connecting to network (Setup Assistant)
9. Bluetooth
10. Standby
11. Volume button and Mute button
12. Submit Diagnostics

TROUBLE SHOOTING

1. The unit does not power on

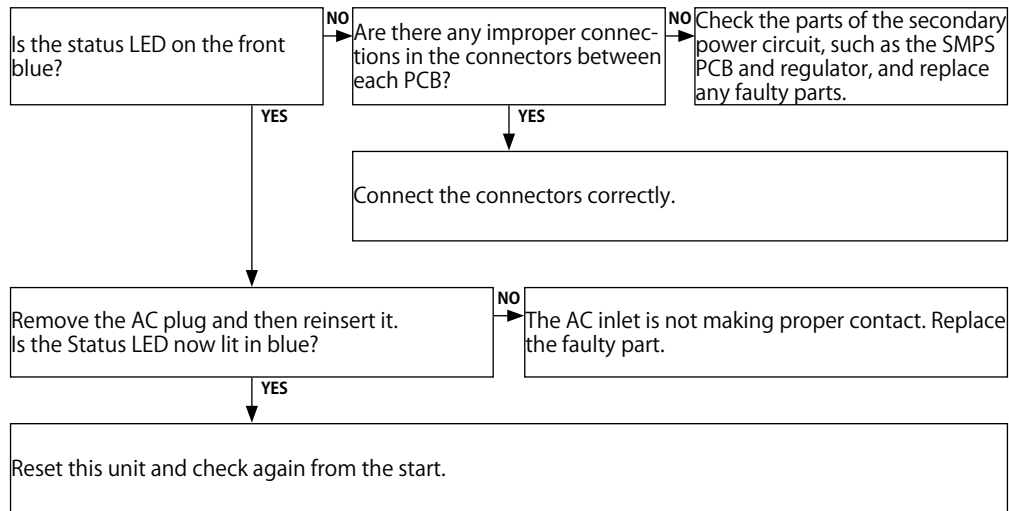

2. No sound from the output speakers

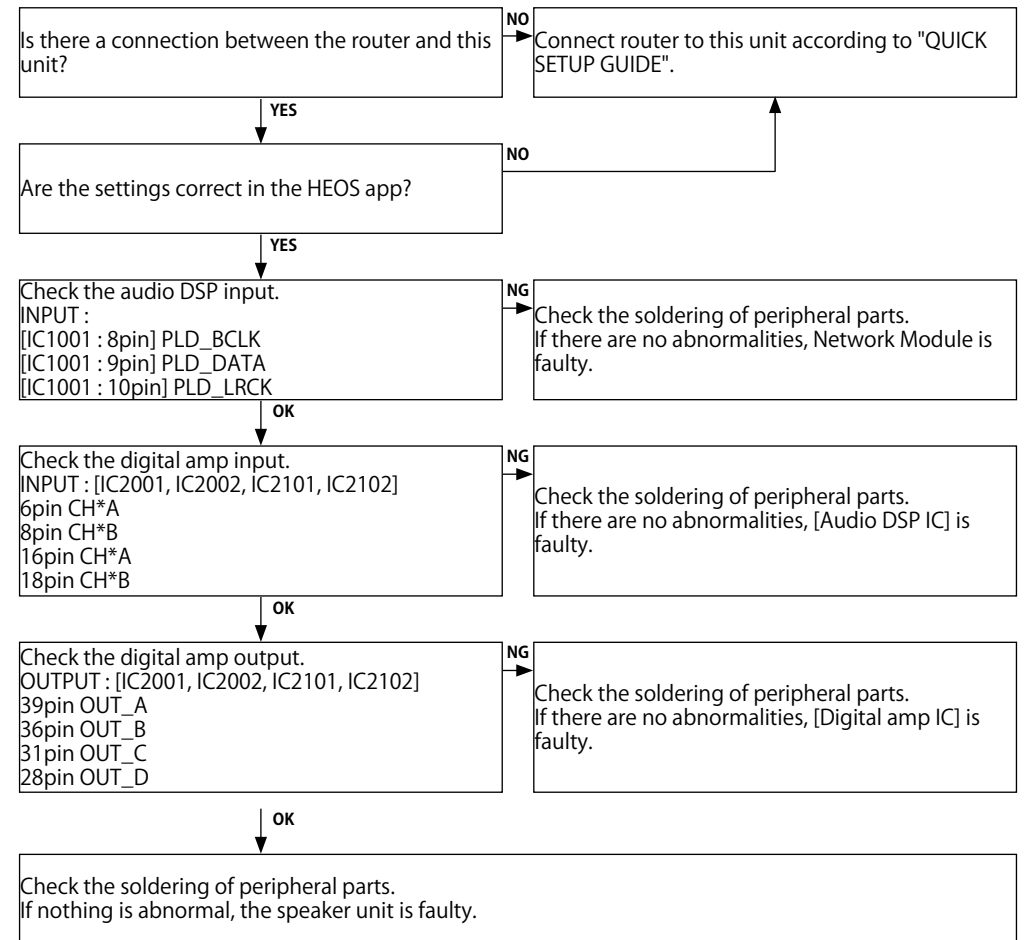

Before Servicing This Unit

Electrical

Mechanical

Repair Information

Updating

3. No sound is output when using the AUX function

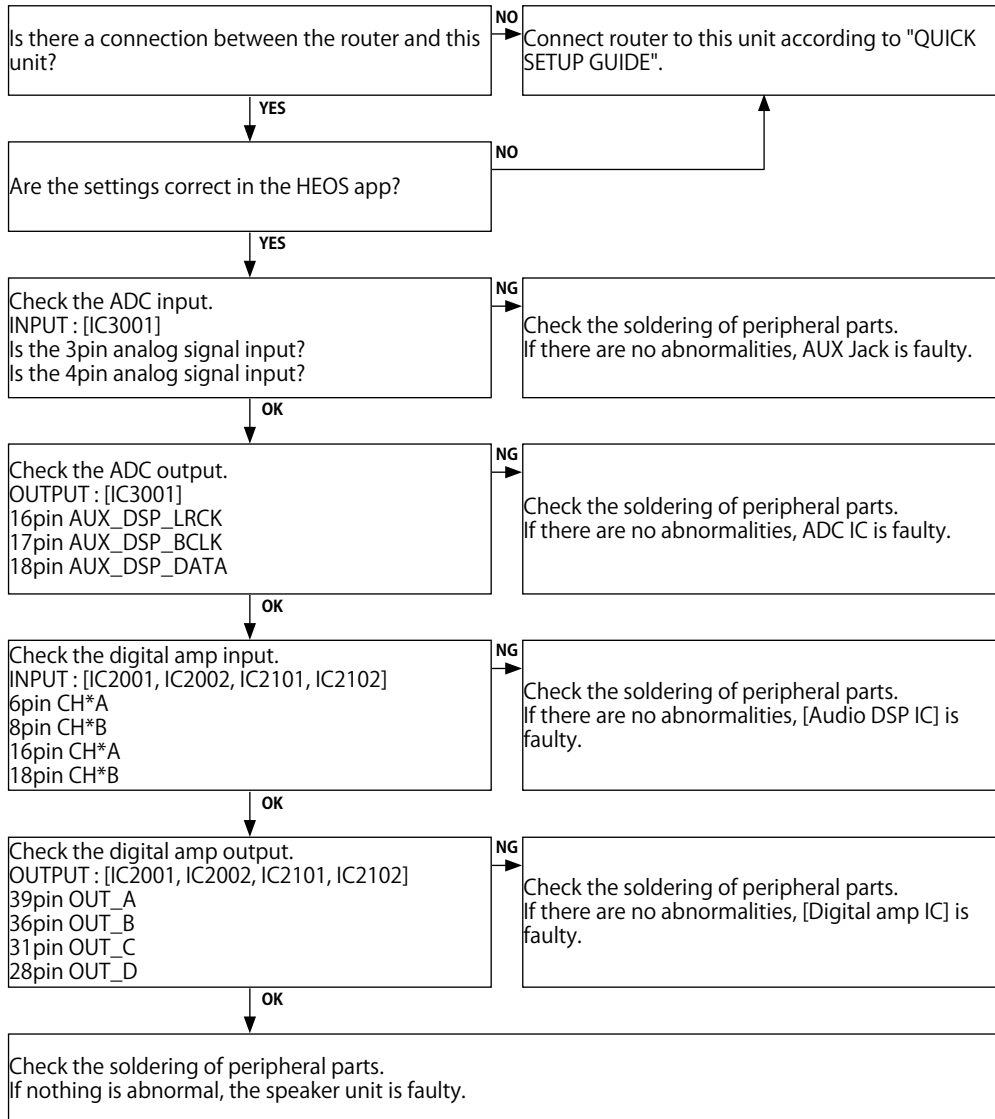

4. Cannot connect to the network by wired LAN

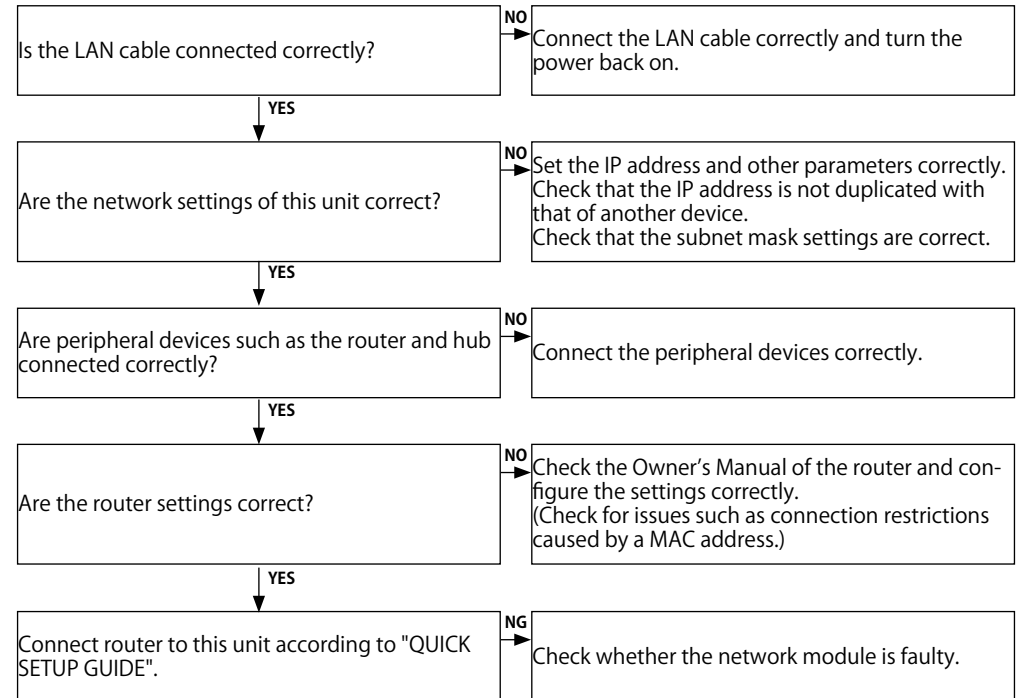

5. Cannot connect to the network by wireless LAN

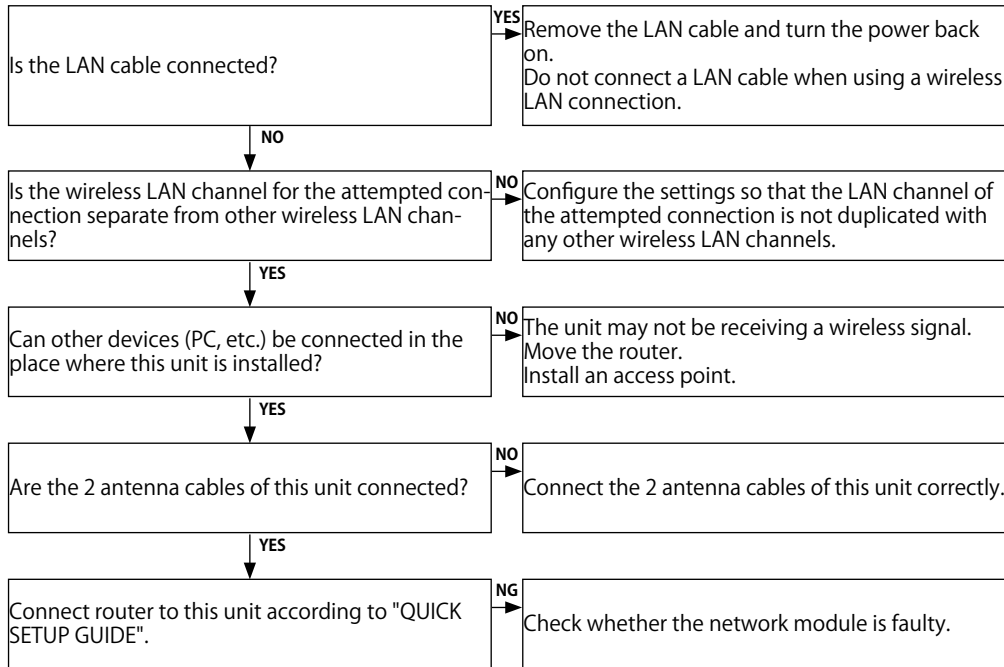

6. USB flash drive not recognized

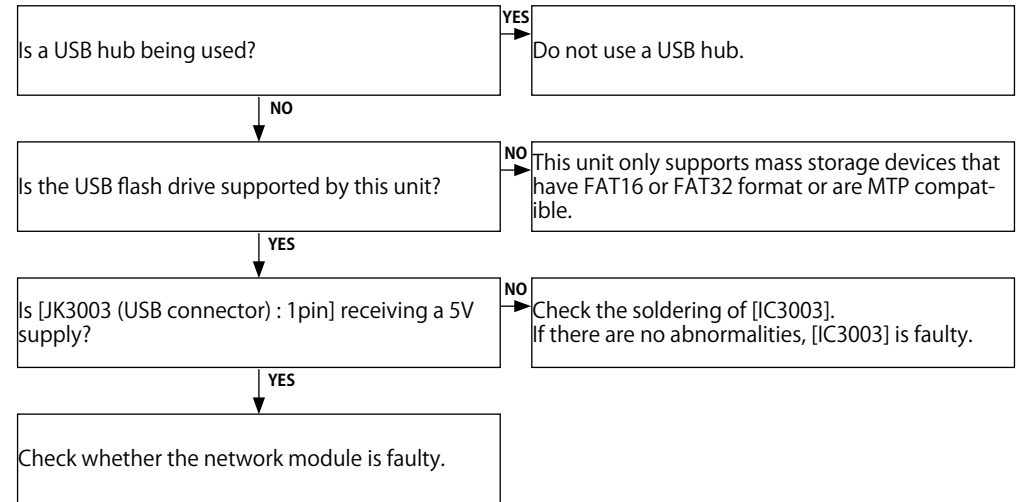

SPECIAL MODE

Special mode setting button

- ※ No. 1 : Insert the AC plug while pressing "A" button, and wait for more than 5 seconds.
- ※ No. 2 : While the power is on, hold down buttons "A" and "B" for at least 5 seconds .

No.	Mode	Button A	Button B	Descriptions
1	Factory Initialization Mode	Bluetooth	-	Various user settings are cleared. and the software is restored to the factory version.
2	User Initialization Mode	Bluetooth	Connect	Various user settings are cleared.

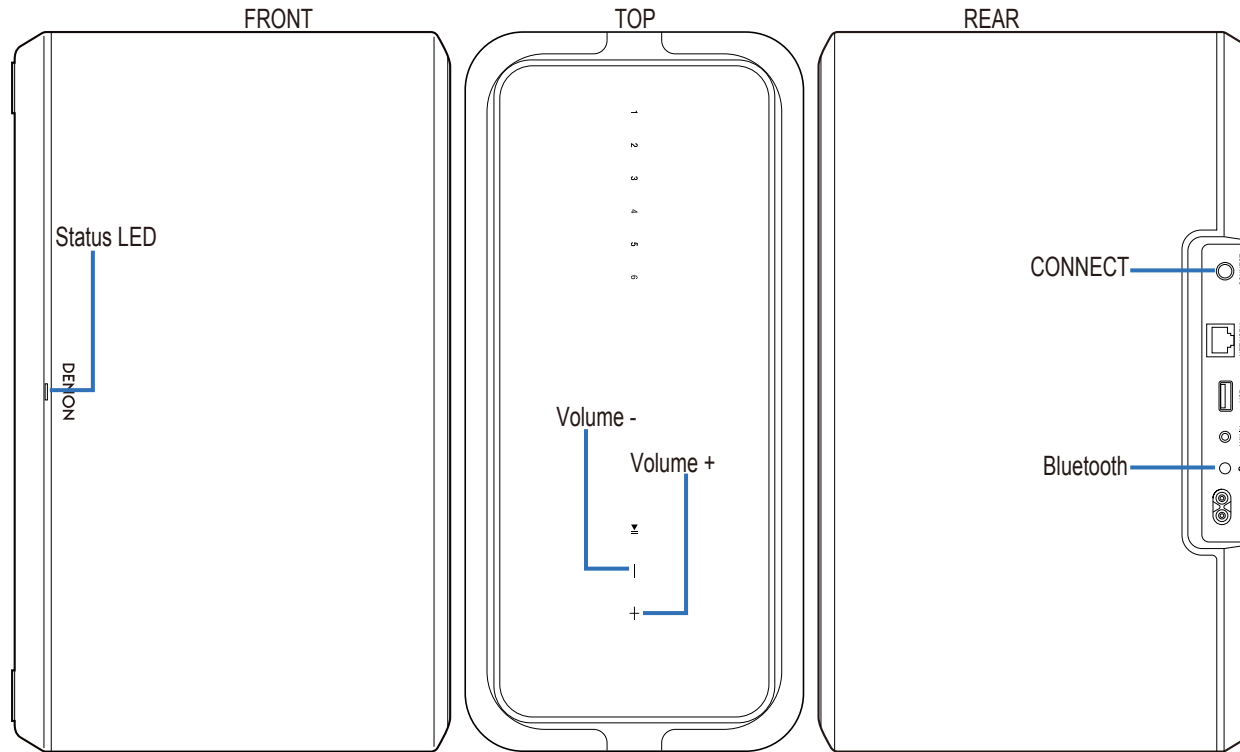

1. Factory Initialization Mode

1.1. Actions

Various user settings are cleared. and the software is restored to the factory version.

1.2. Operations

- (1) Remove the AC plug.
- (2) Insert the AC plug while pressing "**Bluetooth**" button, and wait for more than 5 seconds.
- (3) Check that the Status LEDs is now blinking in orange and then release the button.
- (4) The Status LED blinks in orange while this unit is initializing.
- (5) This unit automatically restarts when initialization is complete.

1.3. Initialization item

No	Items	Default
1	My Devices name	Cleared
2	Network information	Cleared
3	EQ and various user settings	Cleared
4	Firmware	Factory setting

2. User Initialization Mode

2.1. Actions

Various user settings are cleared.

2.2. Operations

- (1) While the power is on, hold down the "**Bluetooth**" and "**Connect**" buttons for at least 5 seconds.
- (2) Check that the Status LEDs is now blinking in orange and then release the button.
- (3) The Status LED blinks in orange while this unit is initializing.
- (4) This unit automatically restarts when initialization is complete.

2.3. Initialization item

No	Items	Default
1	My Devices name	Cleared
2	Network information	Cleared
3	EQ and various user settings	Cleared

3. How to check the firmware version, service region settings and service release type

(1) How to check the version of this unit (illustrations below show the DENON HOME 250 model)
Perform the operations below to display the "About" menu from the "Settings" menu of the HEOS app.

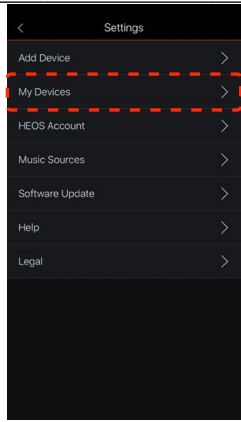
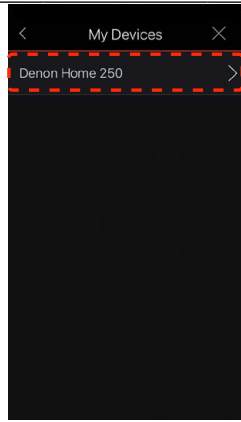
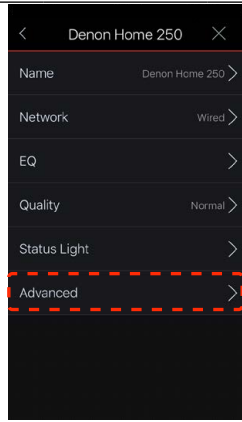
Step 1	Step 2	Step 3
Tap the "My Devices".	Tap the "This unit".	Tap the "Advanced".
		

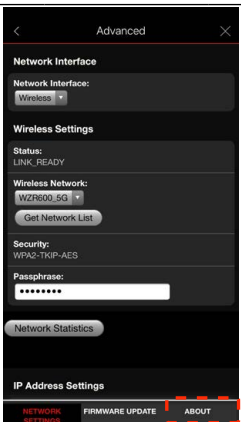
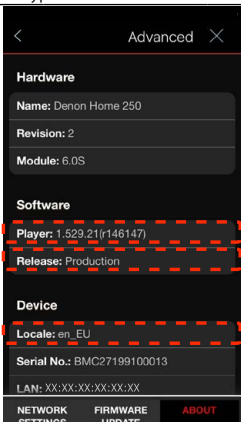
Step 4	Step 5
Tap the "About".	Check the displayed Version, Region and Release Type.
	

Player : Firmware version
Release : Service Release Type
Locale : Service region settings

(2) How to check the version of the "HEOS Apps"
Perform the operations below to display the "About" menu from the "Help" menu of the Heos app.

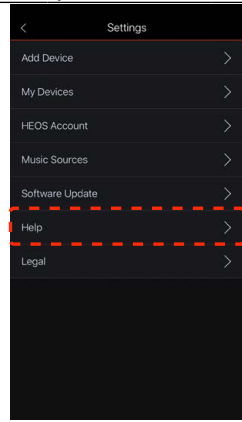
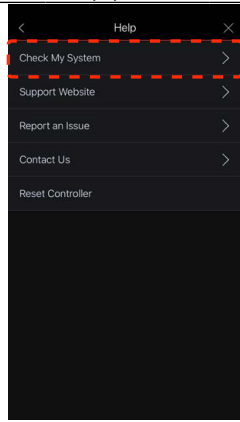
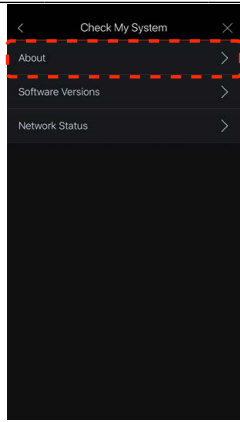
Step 1	Step 2	Step 3
Tap the "Help".	Tap the "Check My System".	Tap the "About".
		

Step 4
Check the displayed version.

Scroll down

Scroll up

Version : App version

4. Service region settings update procedures

Copy the Service Region Settings from the USB flash drive to this unit.

4.1. Items to Be Prepared

- Windows PC
- USB flash drive format : Prepare a USB flash drive formatted in FAT16 or FAT32.

NOTE :

- Do not run the USB flash drive through a hub.
- Do not connect a computer to the USB port of this unit using a USB cable.
- Do not use an extension cable when connecting the USB flash drive.
- If a USB flash drive cannot be updated, replace it with a different USB flash drive and perform the update again.

4.2. Creating a Service Region Settings file

(1) Click [Start button] - [Accessories] - [notepad] on the PC to launch the notepad.

(2) Enter "TEXT".

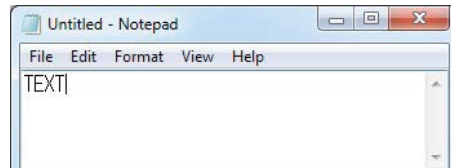

(3) Click "File", and then click "Save As...".

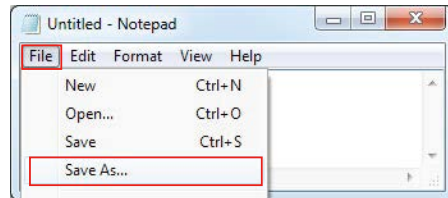

(4) Enter the file name and click the Save button.

NOTE : Enter the file name in double quotation marks. (The file extension is not required.)

Service Region	File name
North America	"denon-config-locale-set-1"
Europe	"denon-config-locale-set-2"
Japan	"denon-config-locale-set-3"
Australia	"denon-config-locale-set-4"
Korea	"denon-config-locale-set-5"
China	"denon-config-locale-set-6"
Israel	"denon-config-locale-set-7"

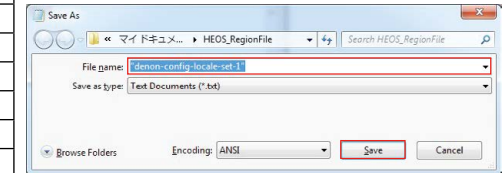

(5) Copy the files created on the USB flash drive.

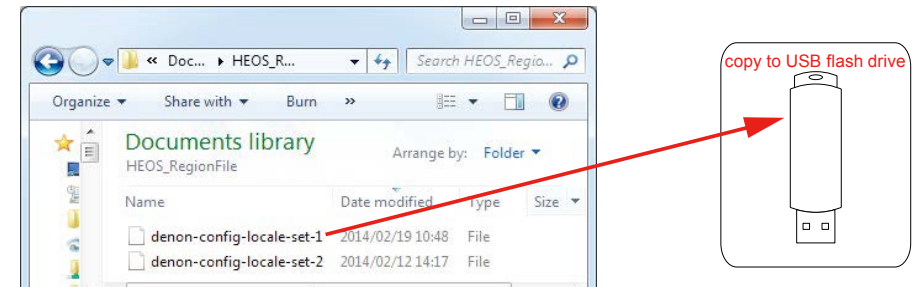

4.3. Inserting a USB flash drive in the USB port

(1) Insert a USB flash drive containing the file created by the above procedure into the USB port on the back panel of this unit.

(2) Check that the LED on the front panel of this unit is blinking, then remove the USB flash drive from this unit.

The Service Region Settings are now complete.

5. Service Release Type settings update procedures

Copy the Service Release Type settings from the USB flash drive to this unit.

5.1. Items to Be Prepared

- Windows PC
- USB flash drive format : Prepare a USB flash drive formatted in FAT16 or FAT32.

NOTE :

- Do not run the USB flash drive through a hub.
- Do not connect a computer to the USB port of this unit using a USB cable.
- Do not use an extension cable when connecting the USB flash drive.
- If a USB flash drive cannot be updated, replace it with a different USB flash drive and perform the update again.

5.2. Creating a Service Release Type Settings file

(1) Click [Start button] - [Accessories] - [notepad] on the PC to launch the notepad.

(2) Enter "TEXT".

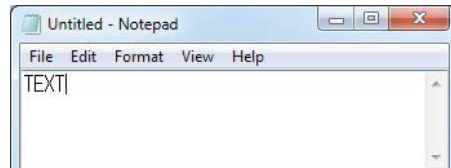

(3) Click "File", and then click "Save As...".

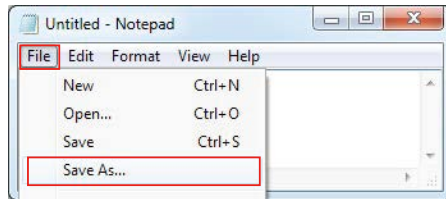

(4) Enter the file name "aios-config-release-type-set-3" and click the Save button.
NOTE : Enter the file name in double quotation marks. (The file extension is not required.)

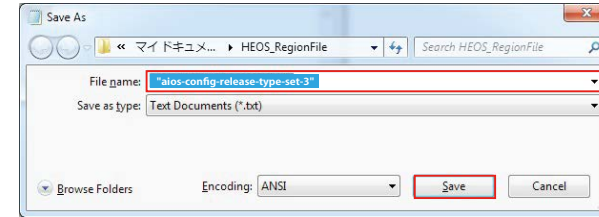

(5) Copy the files created on the USB flash drive.

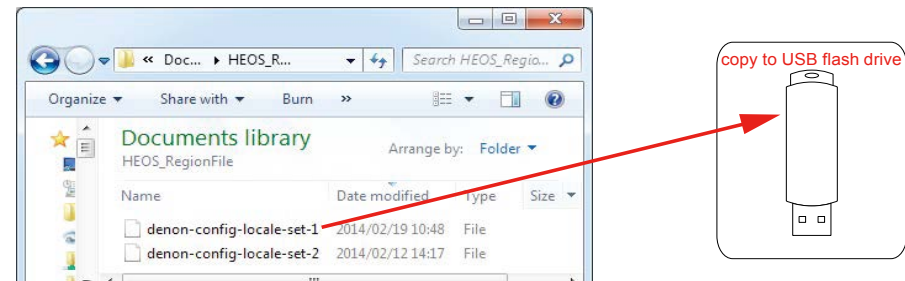

5.3. Inserting a USB flash drive in the USB port

(1) Insert a USB flash drive containing the file created by the above procedure into the USB port on the back panel of this unit.

(2) Check that the LED on the front panel of this unit is blinking, then remove the USB flash drive from this unit.

The Service Release Type settings are now complete.

LED STATUS

1. Updating

The following transition occurs during an update. The same occurs in network and USB updates.

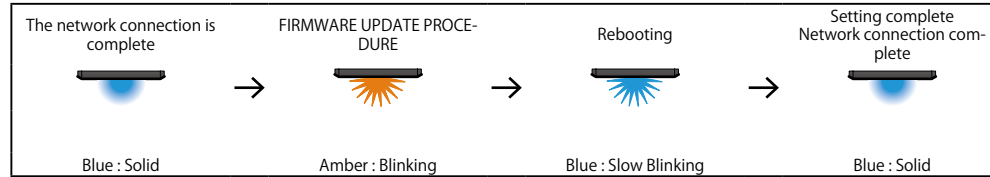

Amber blinking = About 250ms On/Off

2. Updating (Service region settings)

The following transition occurs during a Service Region Settings update.

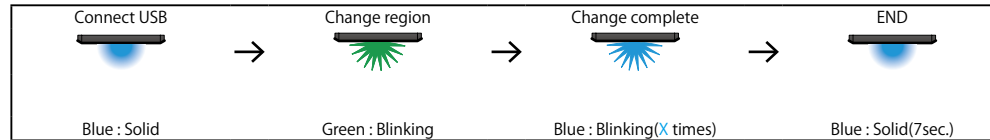

X=The indicator blinks the same number of times as the region number being set. (North America=1, Europe=2, Japan=3, Australia=4, Korea=5)

3. Updating (Service Release Type)

The following transition occurs during a service release type update.

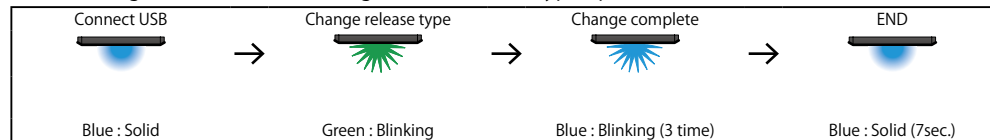

4. On startup of HEOS (when power is turned on)

The following transition occurs on startup.

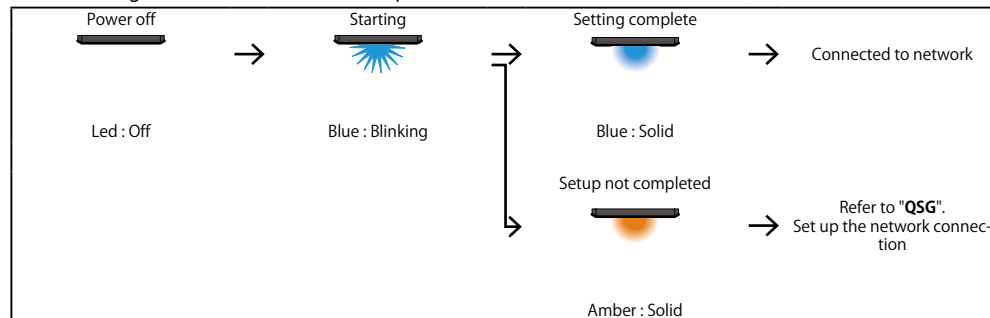

5. Factory Reset

Press and hold the "Bluetooth" button before inserting the power plug, then insert the power plug while holding down the button and wait for more than 5 seconds.

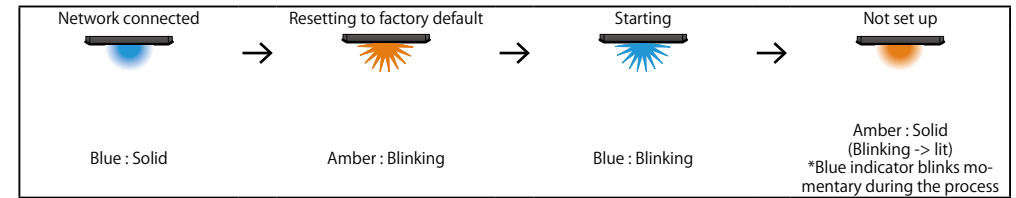

Amber Blinking = About 750ms On/Off : About 130sec

6. Software Reset (Clear user settings)

Press and hold the "Bluetooth" and "Connect" buttons for 5 seconds or more while connected to the network.

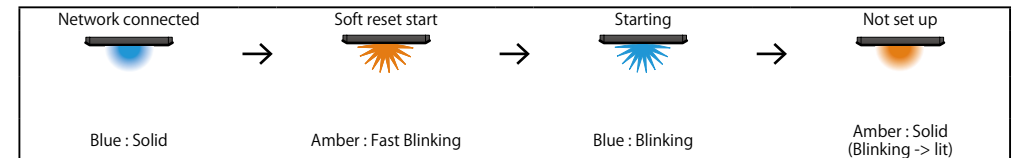

Amber Blinking = About 250ms On/Off : About 25sec

7. Critical Error

The following transition occurs on startup.

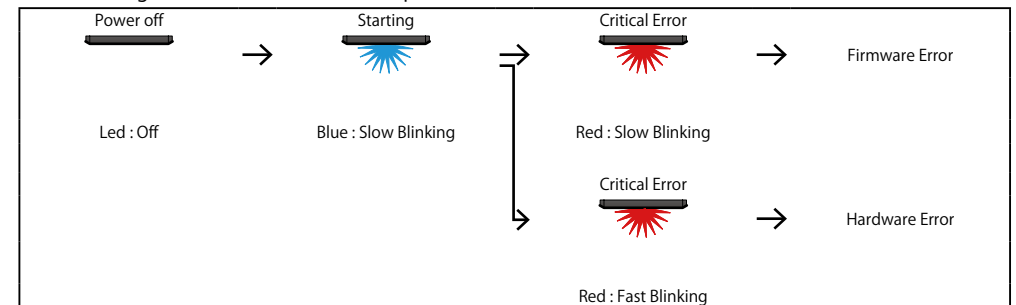

Slow Blinking : 750ms On/Off, Fast Blinking : 250ms On/Off

8. When connecting to network (Setup Assistant)

The following transition occurs during connection to the network. Refer to "QSG".

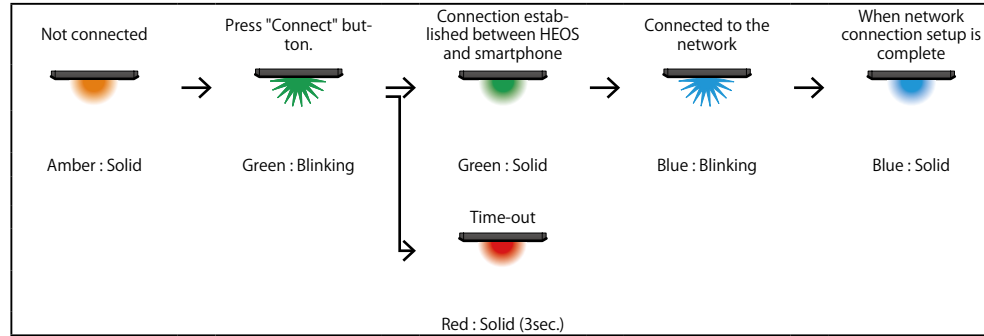

9. Bluetooth

The following transition occurs when the "Bluetooth" button is pressed.

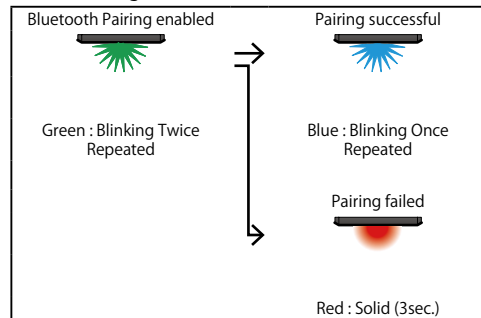

10. Standby

The following transition occurs when this unit switches to standby.

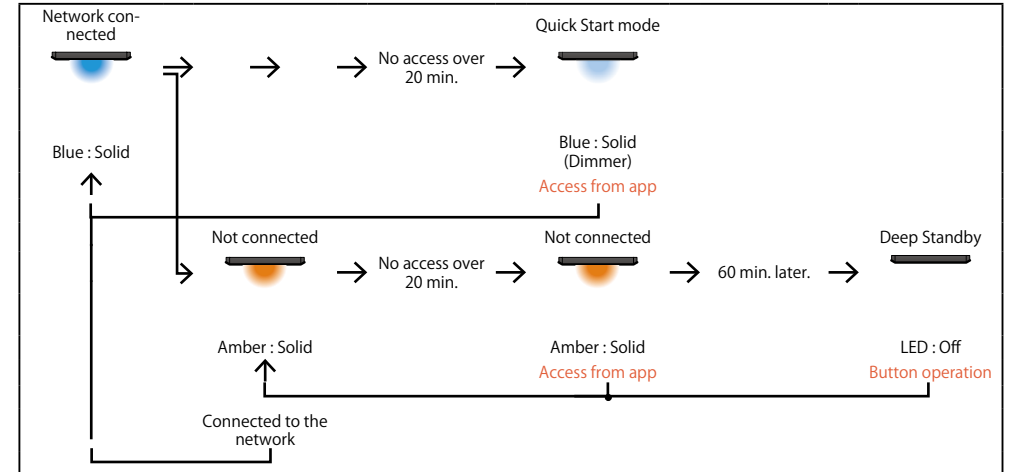

11. Volume button and Mute button

The indicators are lit as shown below when the "Volume" button and "Mute" button are pressed.

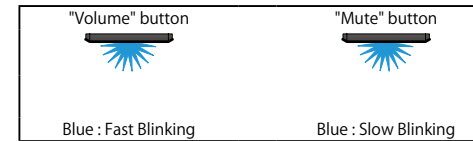

12. Submit Diagnostics

The following transition occurs when "Submit Diagnostics" is performed from the HEOS app.
Operations in HEOS app : **Settings - Advanced - Submit Diagnostics**

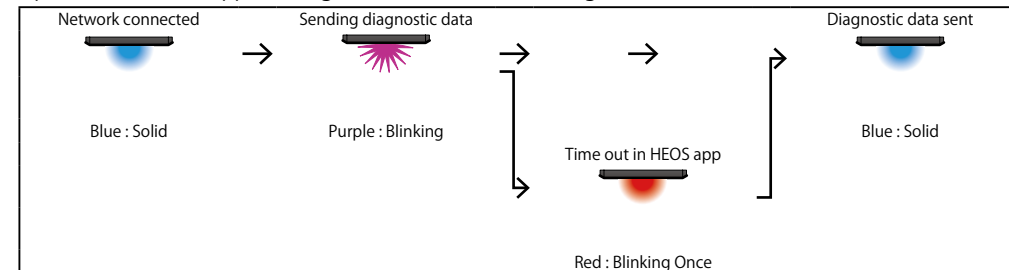

PROCEDURE AFTER REPLACING THE U-COM, ETC.

FIRMWARE UPDATE PROCEDURE

1. Items necessary for update
2. Updating via Network
3. Updating via USB
4. Work flow for writing firmware after changing network module

PROCEDURE AFTER REPLACING THE U-COM, ETC.

The procedure after replacing the u-COM (microprocessor), flash ROM, etc. is as follows.

PCB Name	Ref. No.	Description	Procedure after Re- placement	Remark
MAIN	C3	Network Module	D	SOFTWARE : Network Module
TOUCH	IC8001	CY8C4045AZI-S413	C	SOFTWARE : MCU
MAIN	IC1311	W25X40CLSNIG	C	SOFTWARE : Audio DSP
MAIN	IC5002	MX25L3233F	C	SOFTWARE : VUI DSP

Procedure after Replacement

A : The software has been written. The software is not written at the time of replacement.

B : The software has been written. The software may need to be rewritten by version updates. Check the version.

See "[FIRMWARE UPDATE PROCEDURE](#)" for information on writing the software.

C : The software has not been written. The software needs to be written after replacement.

See "[3. Updating via USB](#)", "[4. Service region settings update procedures](#)" and "[5. Service Release Type settings update procedures](#)" for information on writing the software.

D : The software has been written. Be sure to rewrite with the latest software for your service region.

See "[3. Updating via USB](#)", "[4. Service region settings update procedures](#)" and "[5. Service Release Type settings update procedures](#)" for information on rewrite the software.

FIRMWARE UPDATE PROCEDURE

1. Items necessary for update

Items necessary for update are as follows.

Update Type	Needed Part for Update	Requirement	Offered / not Offered		
			Standard Service Equipment Not offered by D&M	Purchase from D&M Article code	Download from SDI
Via OTA	Smart phone		X	-	-
	Internet Connection by broadband environment	-	X	-	-
	Modem	-	X	-	-
	Router	-	X	-	-
	Ethernet cable (CAT-5 or greater is recommended)	-	X	-	-
Via USB	USB flash drive (USB 2.0 : Min 1GB) • We recommend a USB memory device that has an LED installed.	Formatting FAT16 or FAT 32	X	-	xxxxxxxxx_xxxxxxx.zip

Before Servicing
This Unit

Electrical

Mechanical

Repair Information

Updating

2. Updating via Network

You can update the firmware by downloading the latest version with USB flash drive.

2.1. Items to Be Prepared

- Smart phone
- Broadband Internet connection
- Modem
- Router
- Ethernet cable (CAT-5 or greater is recommended)

2.2. Connection of HEOS

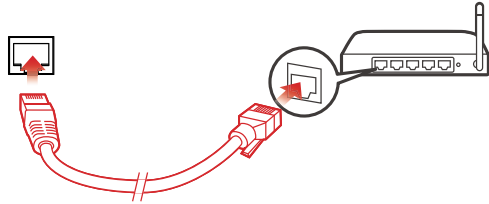

- (1) Search for "**HEOS by Denon**" in the App Store™ or Google Play™ and download the HEOS app for iOS or Android.



- (2) Start the HEOS app.



- (3) If there is a software update, follow steps 1 to 4 below.

Step 1	Step 2	Step 3	Step 4
Tap the "Update Now".	Tap the "Next".	The software is written to this unit.	"Update completed" is displayed. Tap the "Done".
		NOTE : This display is updating two units at the same time.	

- (4) Be sure to rewrite the service region setting.
See "[4. Service region settings update procedures](#)"

4. Work flow for writing firmware after changing network module

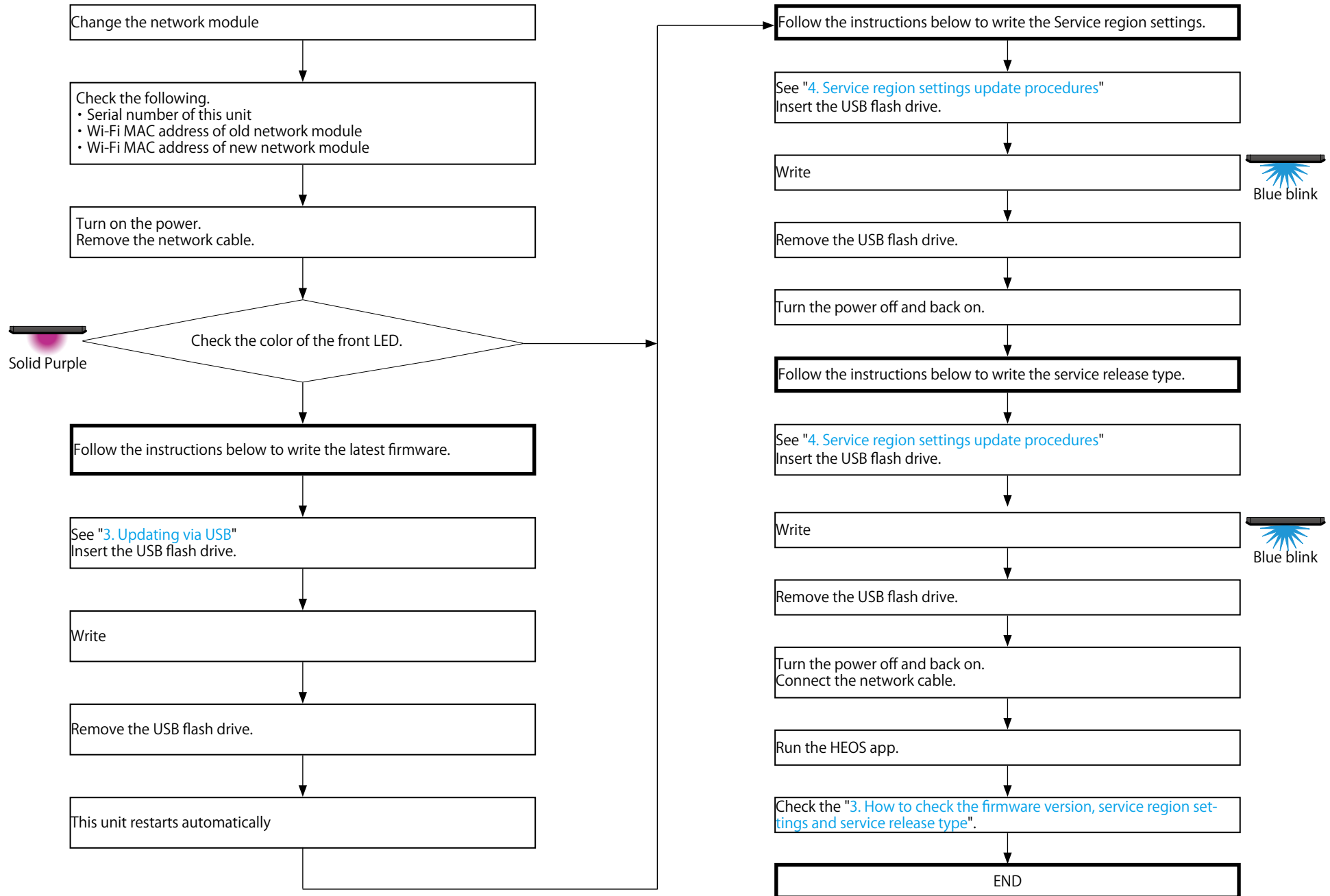

DENON[®]

www.denon.com